

## Electric Circuits II

### I. More about current

For the circuits in this tutorial use the battery holder with two batteries connected in series. The two-battery combination will be treated as a single circuit element.

Set up a two-bulb circuit with identical bulbs so that their terminals are connected together as shown. Bulbs connected in this way are said to be connected in parallel.

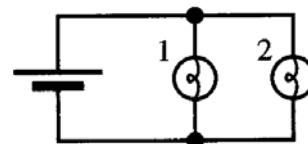

A. Compare the brightness of the bulbs in this circuit.

1. What can you conclude from your observation about the amount of current through each bulb?
  
2. Describe the current through the entire circuit.

B. How does the brightness of each bulb in the two-bulb parallel circuit compare to that of a bulb in a single-bulb circuit? In particular, is each one half as bright?

How does the amount of current through a battery connected to a single bulb compare to the current through a battery connected to a two-bulb parallel circuit? Explain.

C. The circuit at right contains three identical bulbs. Don't set it up! Just *predict*:

- the relative brightness of the bulbs in the circuit
  
- how the brightness of bulb A would change if you unscrewed bulb C

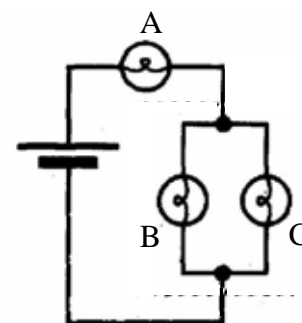

Now check your predictions.

Explain why you *can't* predict how the brightness of bulb B would change if you unscrewed bulb C just by thinking about what happens to the current. (If you think you can, go for it, but double-check with a TA.)

★ Please check with your TA before you go on.

## II. Voltage

- A. Set up a circuit with a single bulb.

Connect each probe of the voltmeter to a different terminal of the battery holder to measure the voltage across the battery.

To measure the voltage across the bulb, connect each probe of the voltmeter to a different terminal of the bulb.

How does the voltage across the bulb compare to the voltage across the battery?

- B. Set up the circuit containing two bulbs in series as shown.

1. Rank from largest to smallest the *currents* through bulb 1, bulb 2, and the bulb in the single-bulb circuit from part A.

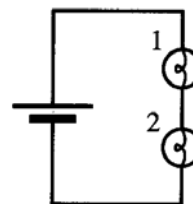

2. Measure the *voltage* across each element in the circuit (fill in the table at right).

$V_{\text{Bat}}$	$V_{\text{Bulb 1}}$	$V_{\text{Bulb 2}}$

- i. How does the voltage across the battery in this circuit compare to the voltage across the battery in the single-bulb circuit? (See part A.)
  
  
  
  
  
  
  
  
  
  
- ii. Rank the voltages across bulb 1, bulb 2, and the bulb in the single-bulb circuit from part A.
  
  
  
  
  
  
  
  
  
  
- iii. How does the voltage ranking compare to the brightness ranking of the bulbs?
  
  
  
  
  
  
  
  
  
  
- iv. *Predict* what the voltmeter would read if it were connected to measure the voltage across the network of bulb 1 and bulb 2 together. Explain.

Test your prediction.

## Tutorial : Electric Circuits II

---

C. Set up the circuit with two bulbs in parallel as shown.

1. Rank the currents through bulb 1, bulb 2, and the bulb in the single-bulb circuit from part A. Explain.

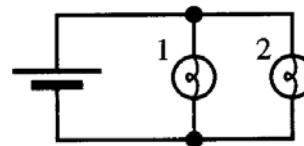

How does the current through bulb 1 compare to the current through the battery?

2. How does the voltage across the network of bulbs compare to the voltage across the battery?

- i. Measure the voltage across each circuit element.
- ii. How does the voltage across the battery in this circuit compare to the voltage across the battery in the single-bulb circuit?

$V_{\text{Bat}}$	$V_{\text{Bulb 1}}$	$V_{\text{Bulb 2}}$

- iii. Rank the voltage across bulb 1, bulb 2, and the bulb in the single-bulb circuit from part A.

3. How does the ranking by voltage compare to the ranking by brightness?

D. Answer the following questions based on the measurements you have made so far.

1. Does the *current through the battery* depend on the circuit to which it is connected? Explain.
2. Does the *voltage across the battery* depend on the circuit to which it is connected? Explain.
3. Can you use the relative brightness of identical bulbs to compare the *current* through them?
4. Can you use the relative brightness of identical bulbs to compare the *voltage* across them?

★ Please check with your TA.

### III. Reasoning with current or voltage

The following questions all involve circuits you've seen before, so the "answer" (which bulbs are brighter than which other bulbs) isn't the point. The point is to think about the *reasoning* you could use to predict and explain the relative brightness of the bulbs.

- A. Three students give predictions and explanations for the relative brightness of bulbs A, B, and C. Identify which students, if any, are reasoning correctly. For the ones not reasoning correctly, offer a response that would help them understand where their thinking went astray.

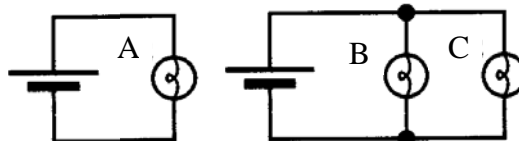

Susan: "B and C will be dimmer than A. Bulb A gets all of the current from the battery but B and C have to share it."

Mariel: "A, B, and C will all be equally bright. They each have the same voltage across them."

Jason: "A, B, and C will all be equally bright. The bulbs are identical, and each is connected directly across the battery, so each bulb has the same amount of current through it. So they are equally bright."

- B. Four students give explanations for the relative brightness of bulbs in the circuit below. Identify which students, if any, are reasoning correctly. For the ones not reasoning correctly, offer a response that would help them understand where their thinking went astray.

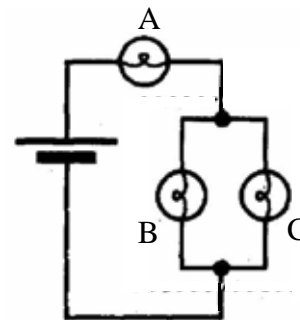

Lauren: "B and C are equally bright but dimmer than A. B and C have to share the current whereas A gets all of it."

Nate: "Bulb A uses up most of the current so less is left for B and C. A is therefore brighter than B or C."

Sheryl: "After bulb A, the voltage divides into two paths with the result that B and C each get less voltage than A. Therefore A is brighter than B or C."