

Black Holes and Warped Spacetime

Ted Jacobson

Picture by Roger Penrose
The Road to Reality (Knopf, 2005)

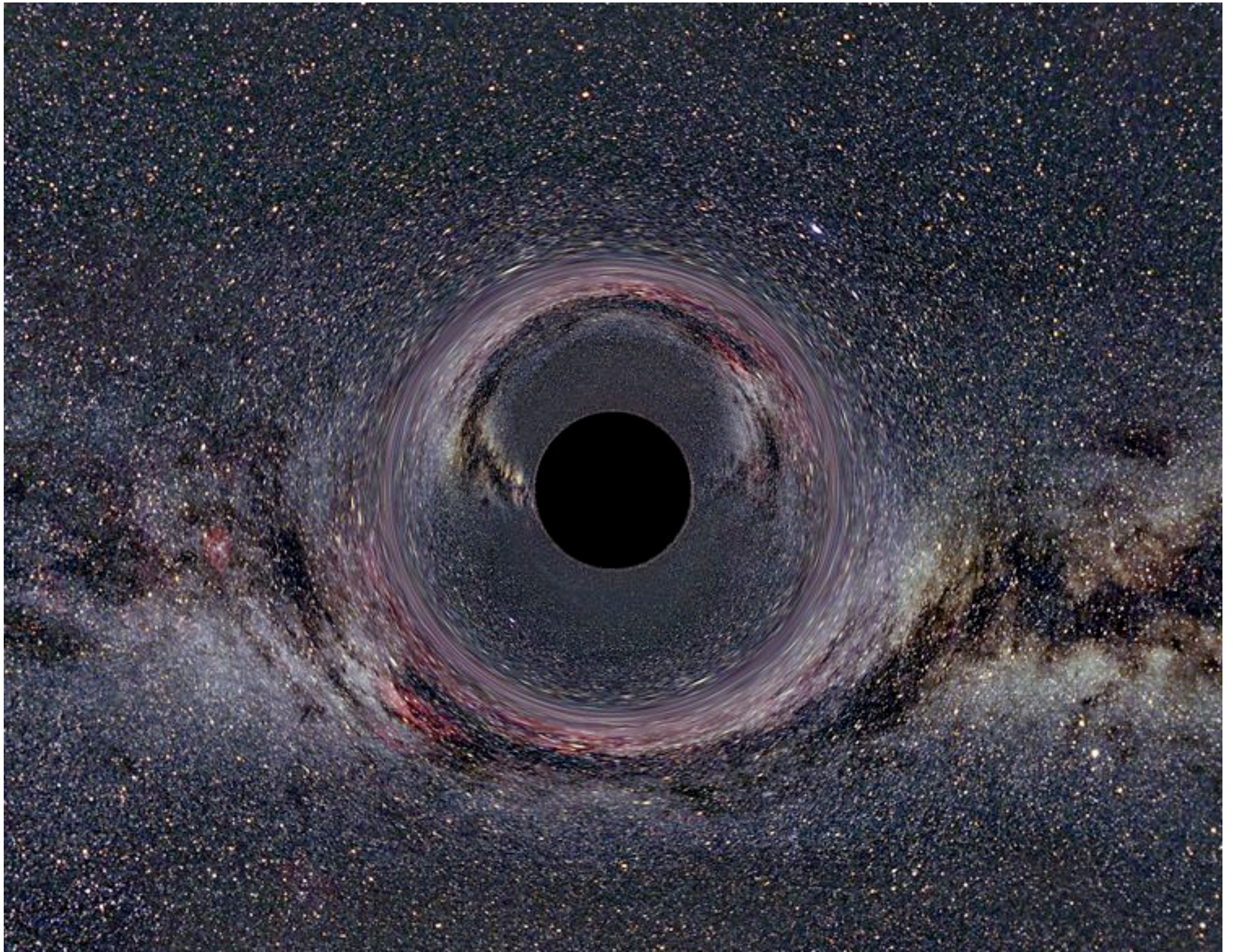

Gravity



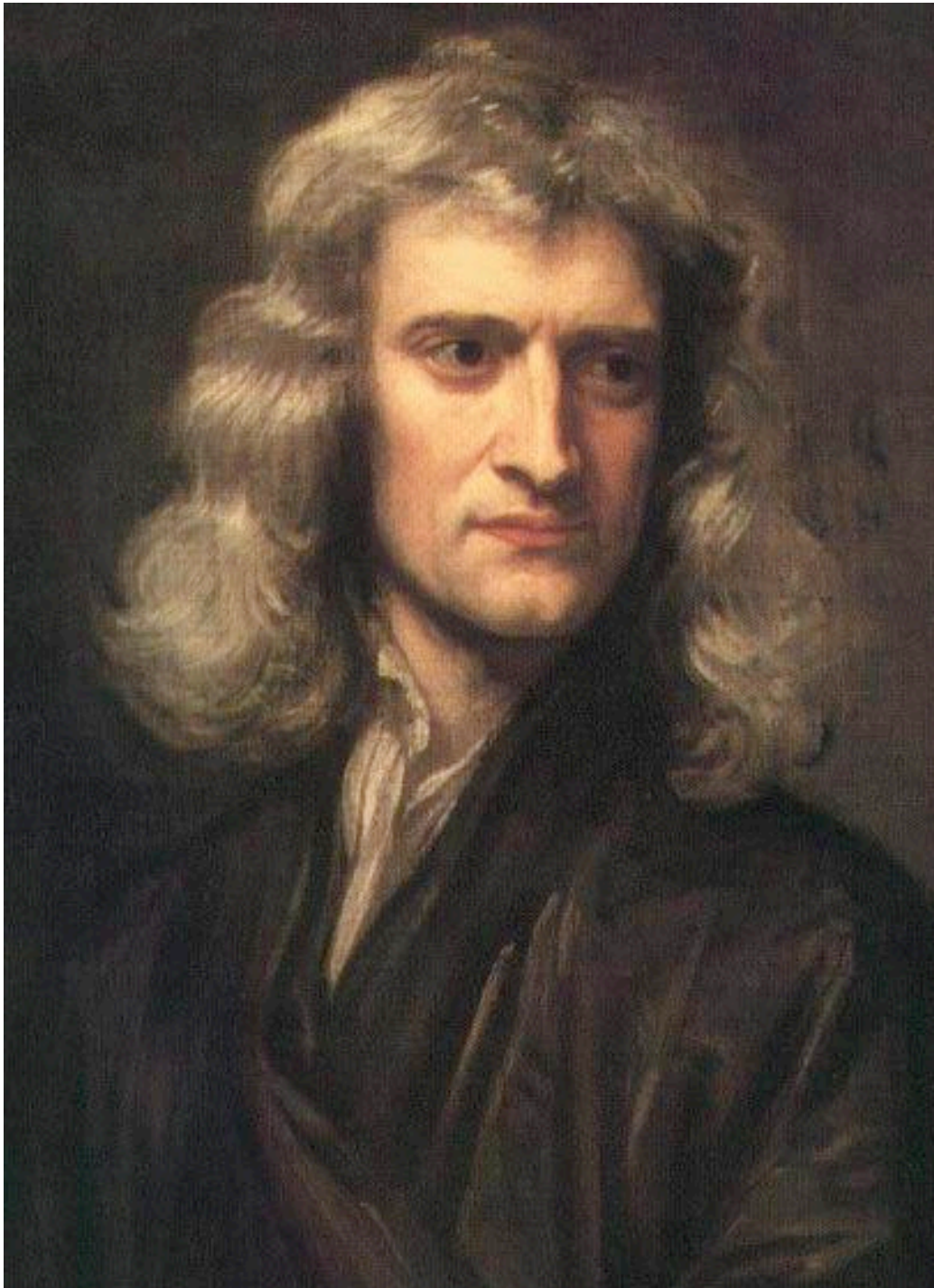

Gravity

is a force of attraction between any two masses, proportional to each mass and inversely to the square of their separation.

With this Newton unified the fall of an apple, the tides, and the orbits of the moon and the solar system.

Isaac Newton, aged 46, 1689

Escape velocity



Escape velocity



Escape velocity

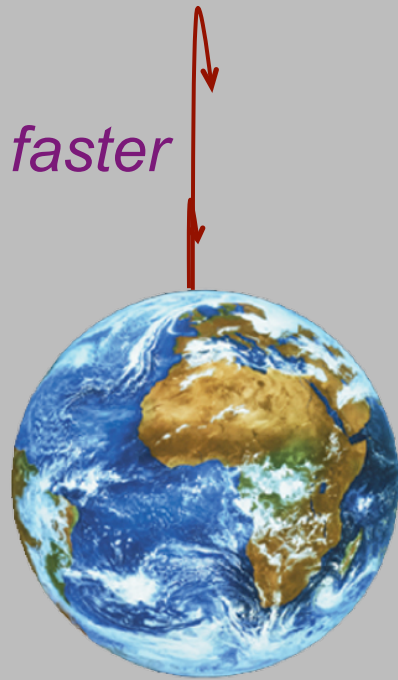

Escape velocity

faster yet

faster



Escape velocity

fast enough



faster yet



faster



fast enough

Escape velocity

$$\frac{1}{2} m v_{esc}^2 = GMm/R$$

faster yet

v_{esc} is speed of light if R small enough:

faster

$$R = 2GM/c^2 = \frac{1}{4} " (M/M_{earth}) \\ = 3 \text{ km} (M/M_{sun})$$



If Sun were compressed to a radius of 3 km, **keeping the mass the same**, the escape velocity would be the speed of light ...

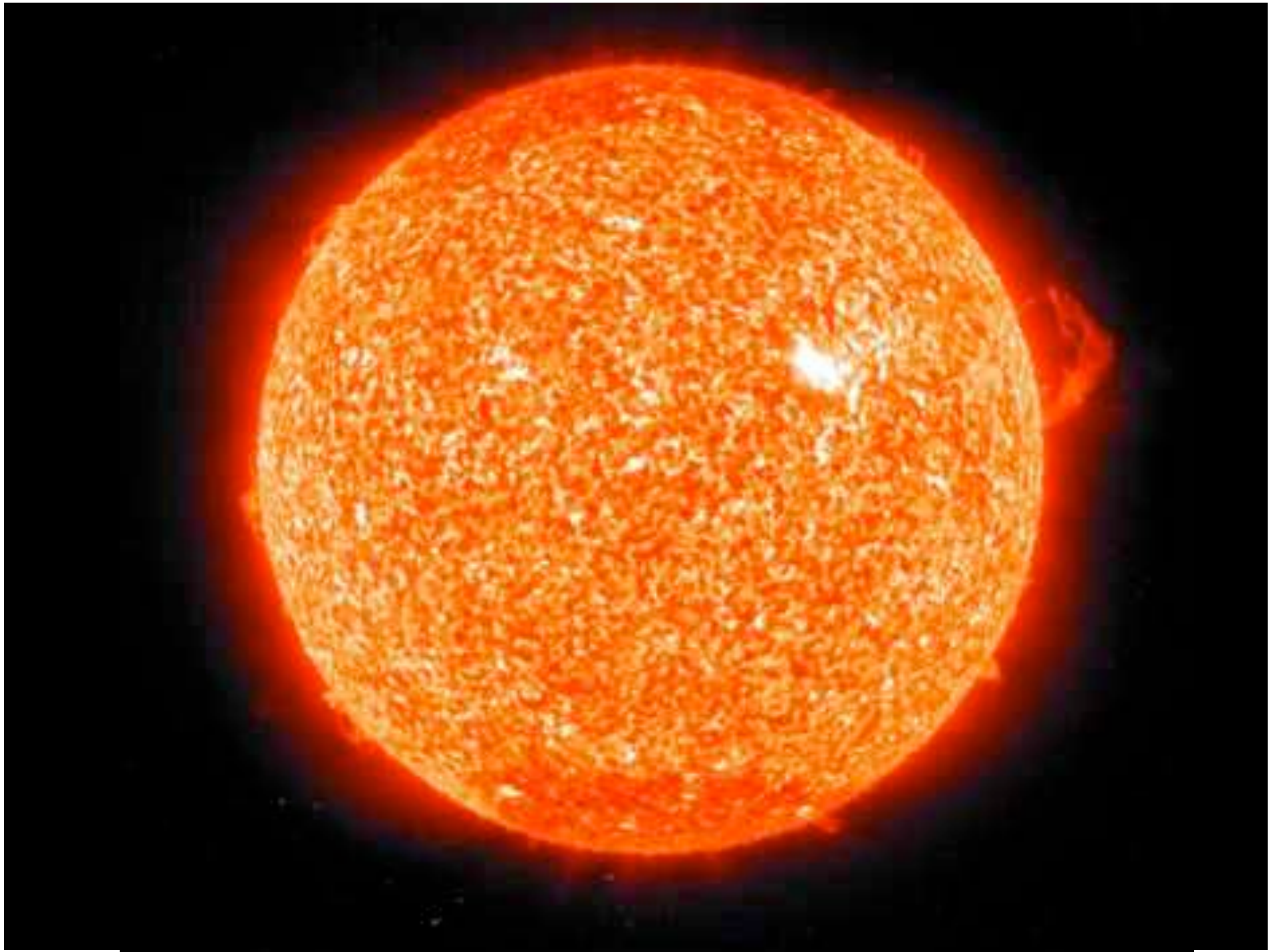







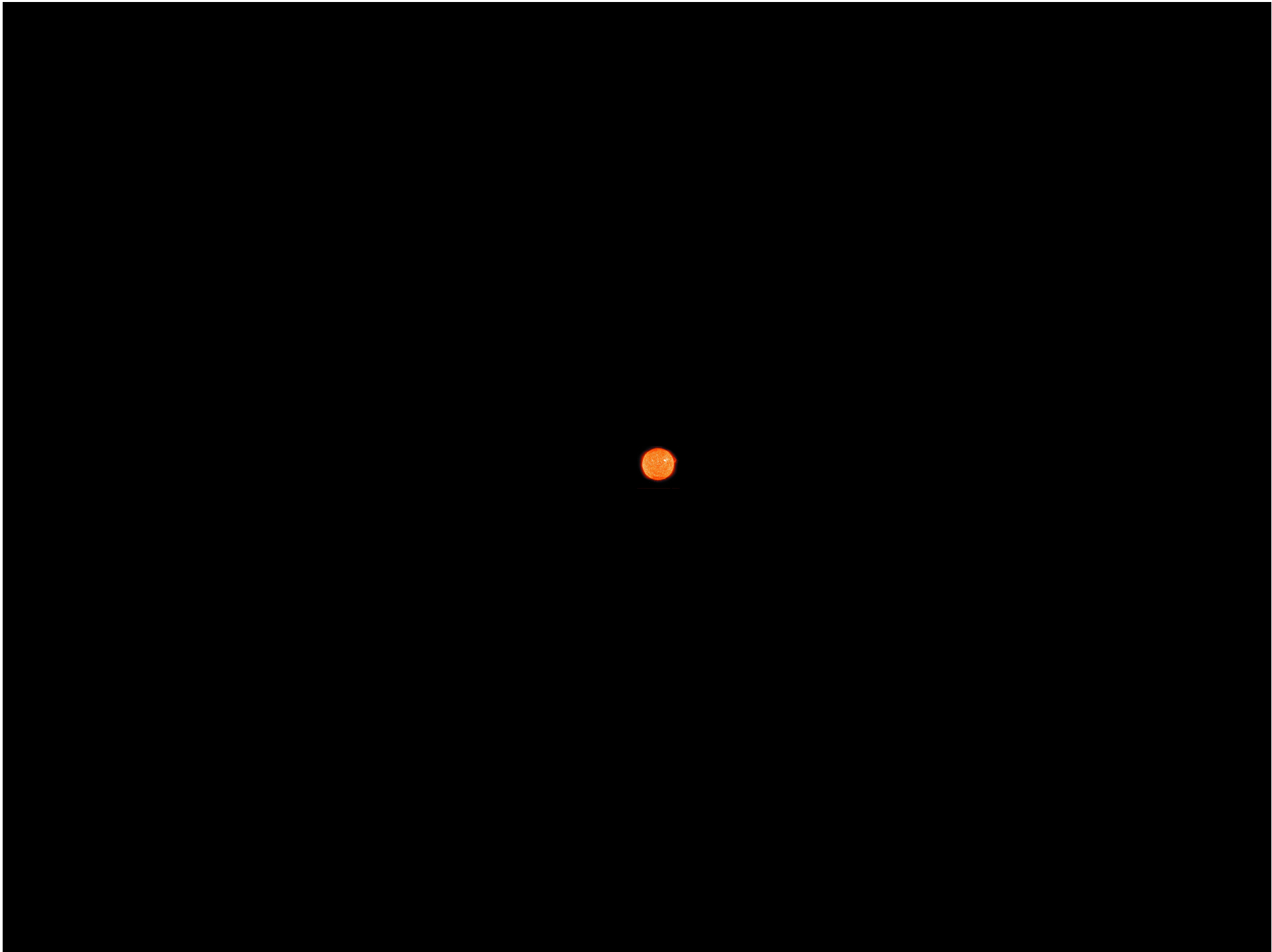

...but to deal with objects moving at the speed of light,
we need to use Einstein's special relativity theory...

•

...and to deal with extremely strong gravity,
we need to use Einstein's general relativity theory...

Special Relativity Theory Einstein, 1905

Light is always propagated in empty space with a definite velocity c which is independent of the state of motion of the emitting body or the observer.

This led to a new view of the world,
replacing “space over time” by

“spacetime”



A spacetime analogy



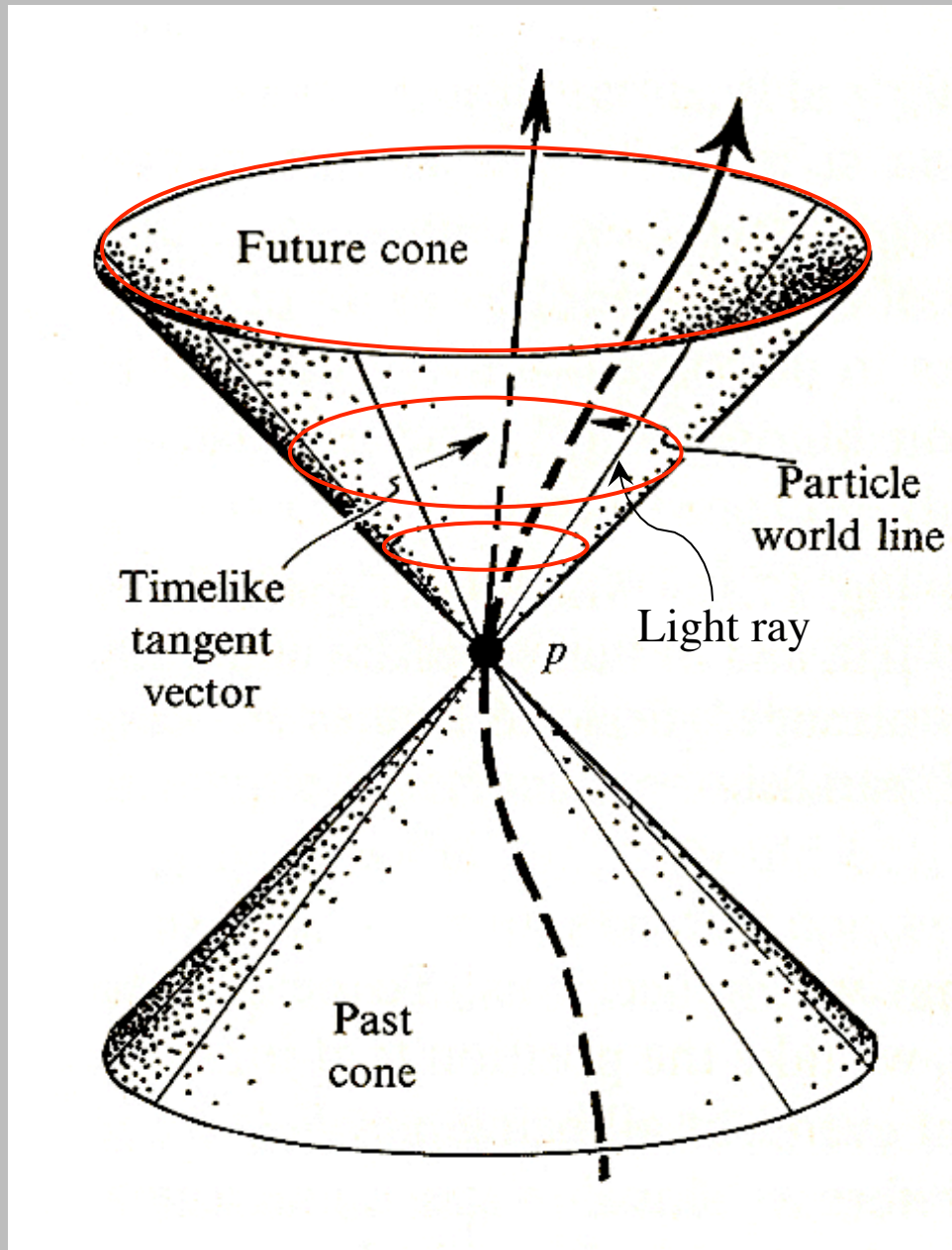

The Light Cone

paths of light light rays in spacetime

No time passes for something moving at the speed of light along a light ray



Gravity cannot be held responsible for people falling in love.



“I was sitting in my chair in the Patent Office in Bern when all of a sudden a thought occurred to me: ‘If a person falls freely, he won’t feel his own weight.’ I was startled. This simple thought made a deep impression on me...”

“At this point there occurred to me the happiest thought of my life...”

“...if one considers an observer in free-fall, e.g., from the roof of a house, there exists for him during this fall no gravitational field --- at least not in his immediate vicinity.”



So *true* gravity is the *relative acceleration* of falling bodies...or light rays.

Special relativity: spacetime

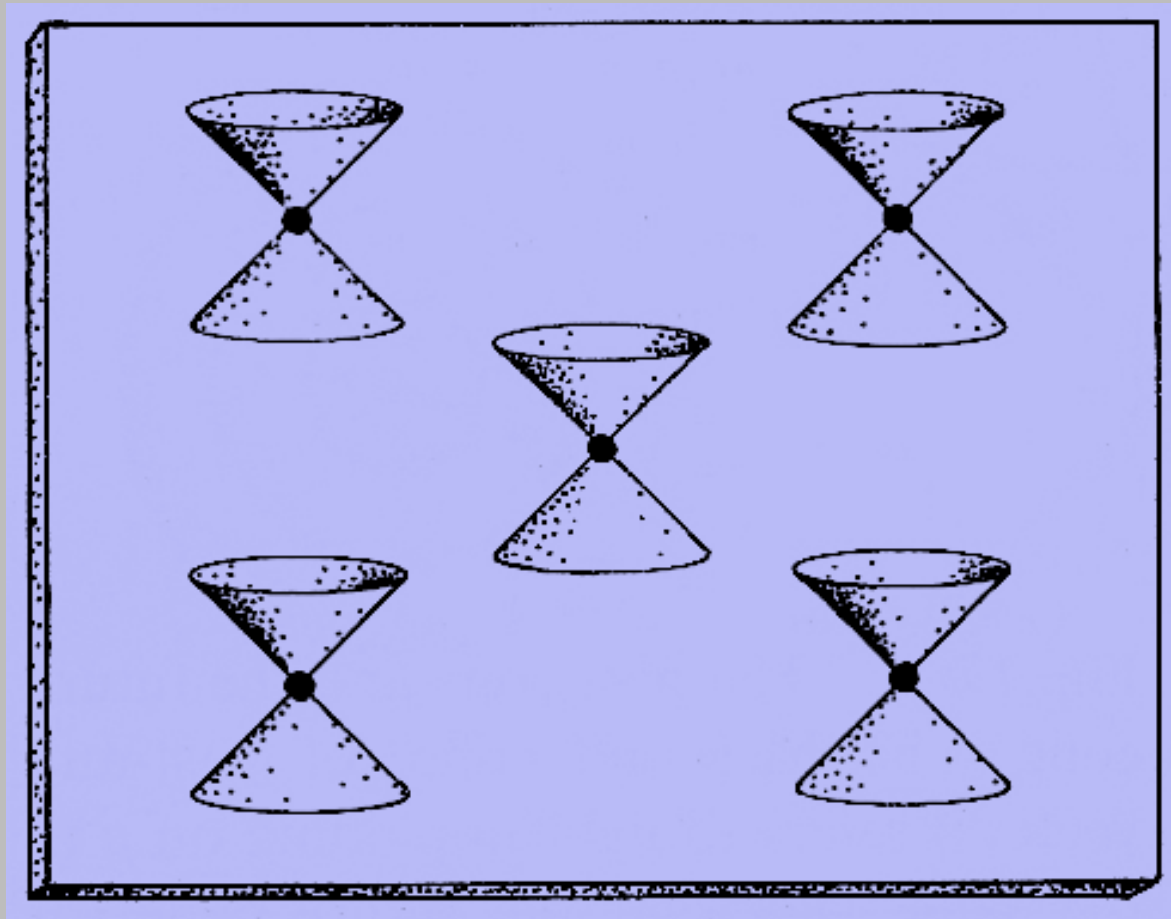

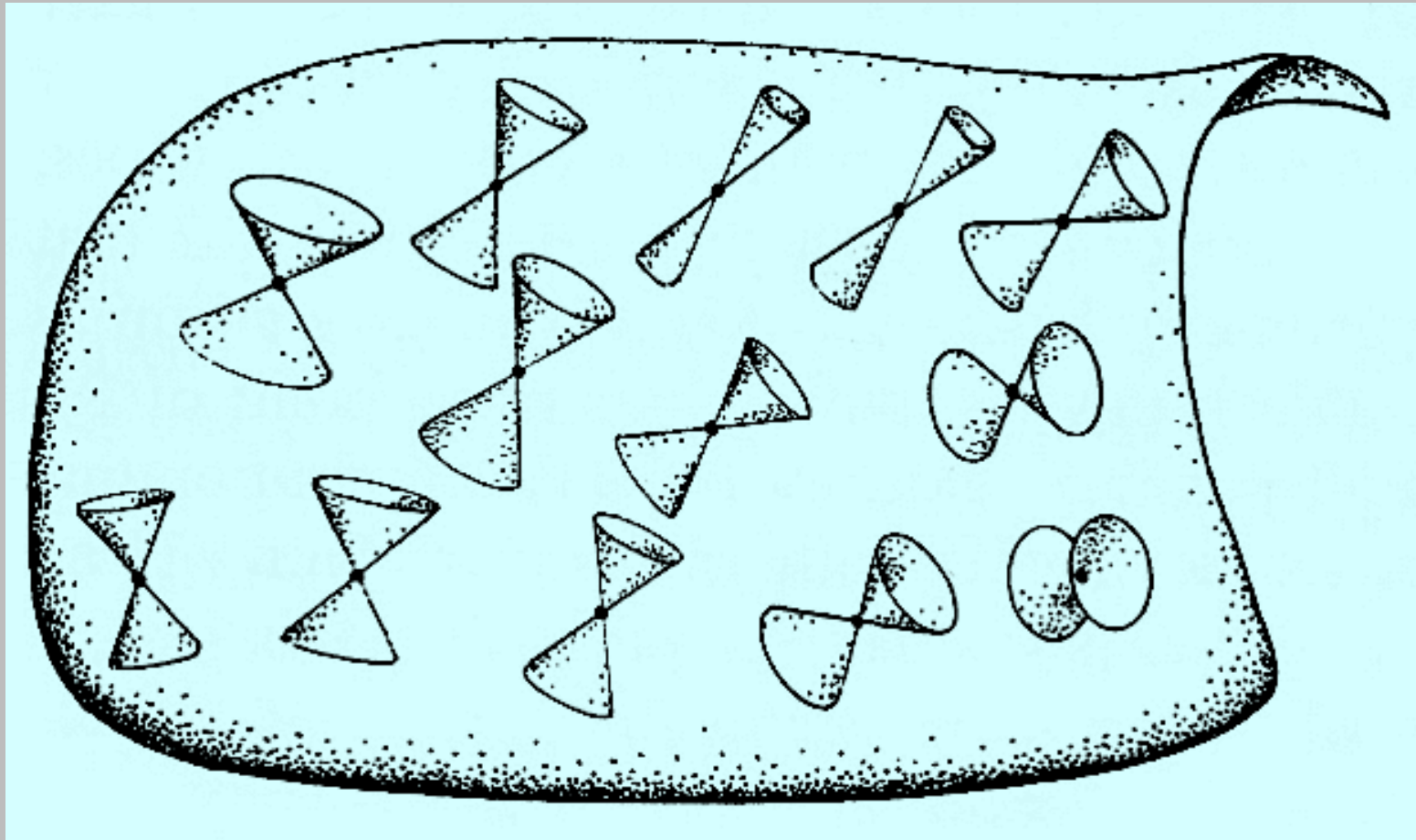

General relativity:
Gravity is nothing but *curvature* of spacetime

A black hole analogy



A black hole analogy

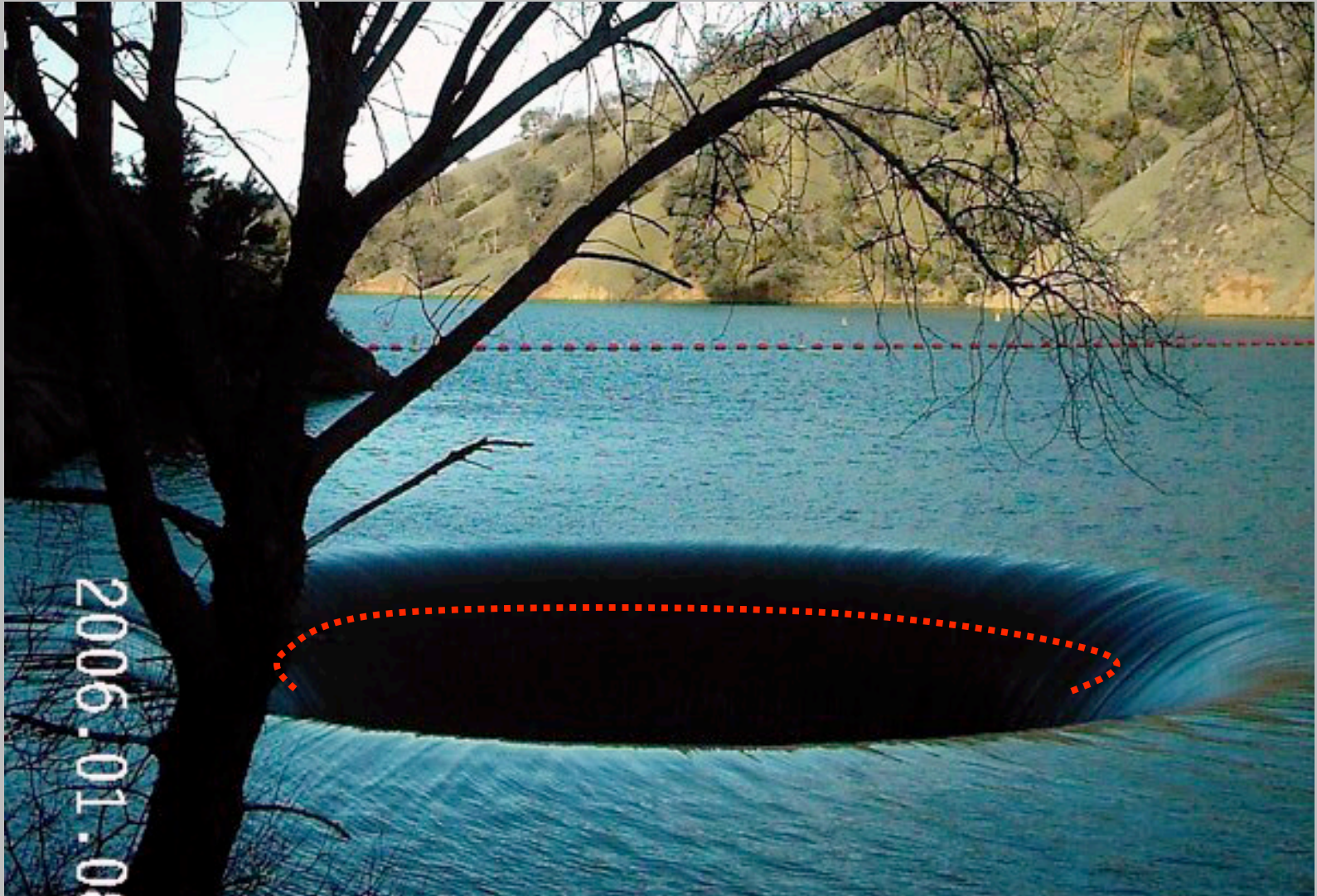

A black hole analogy

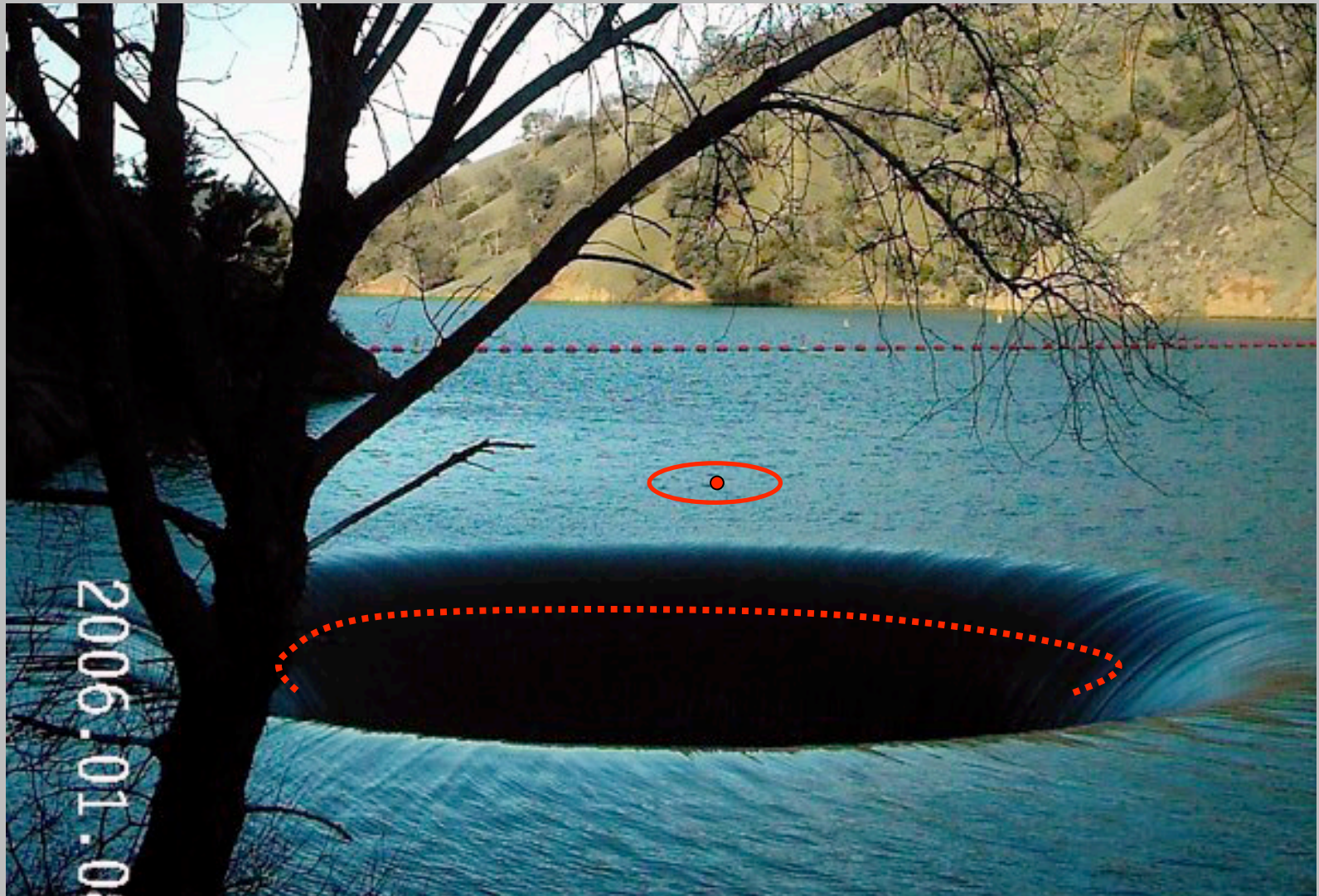

A black hole analogy

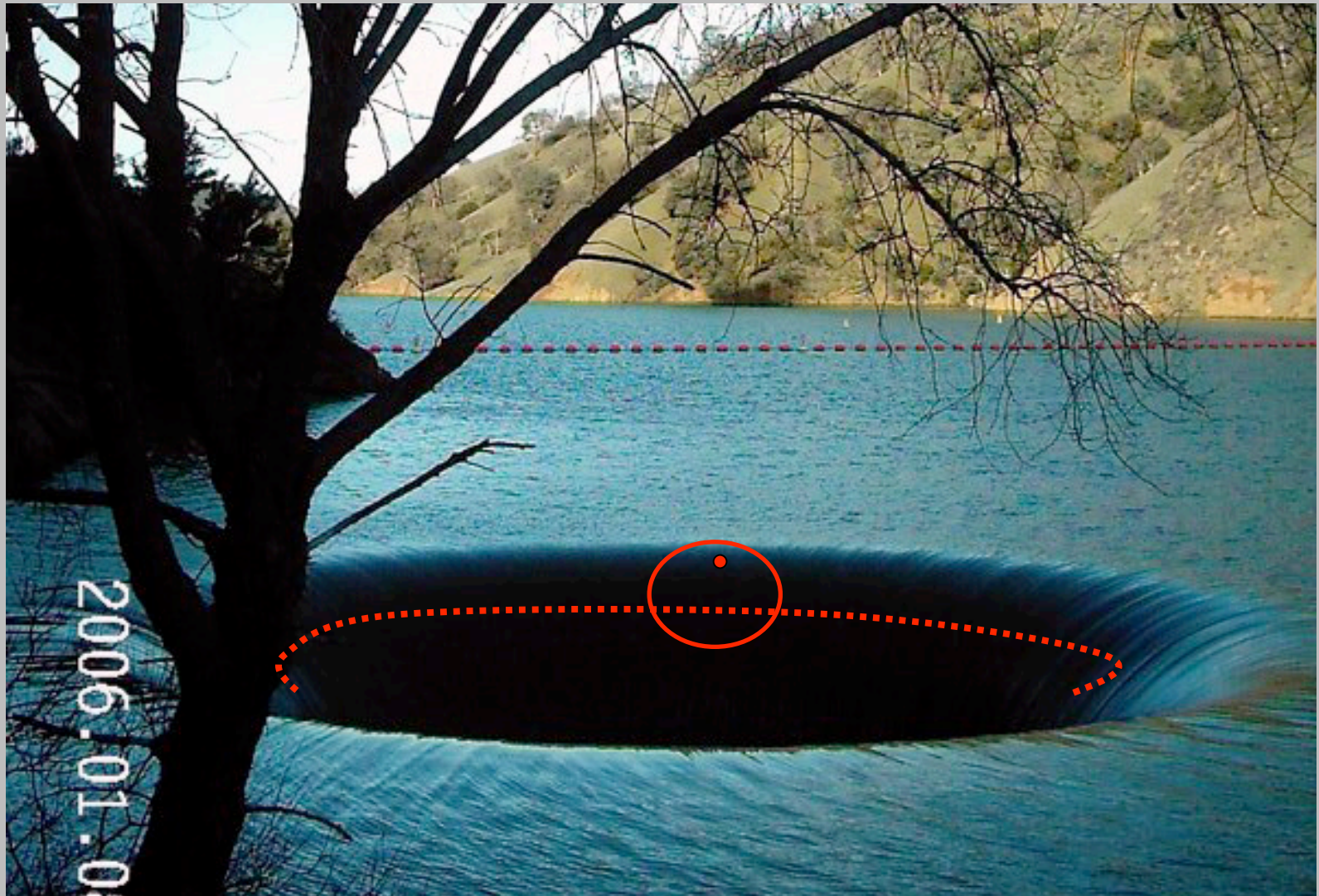

A black hole analogy

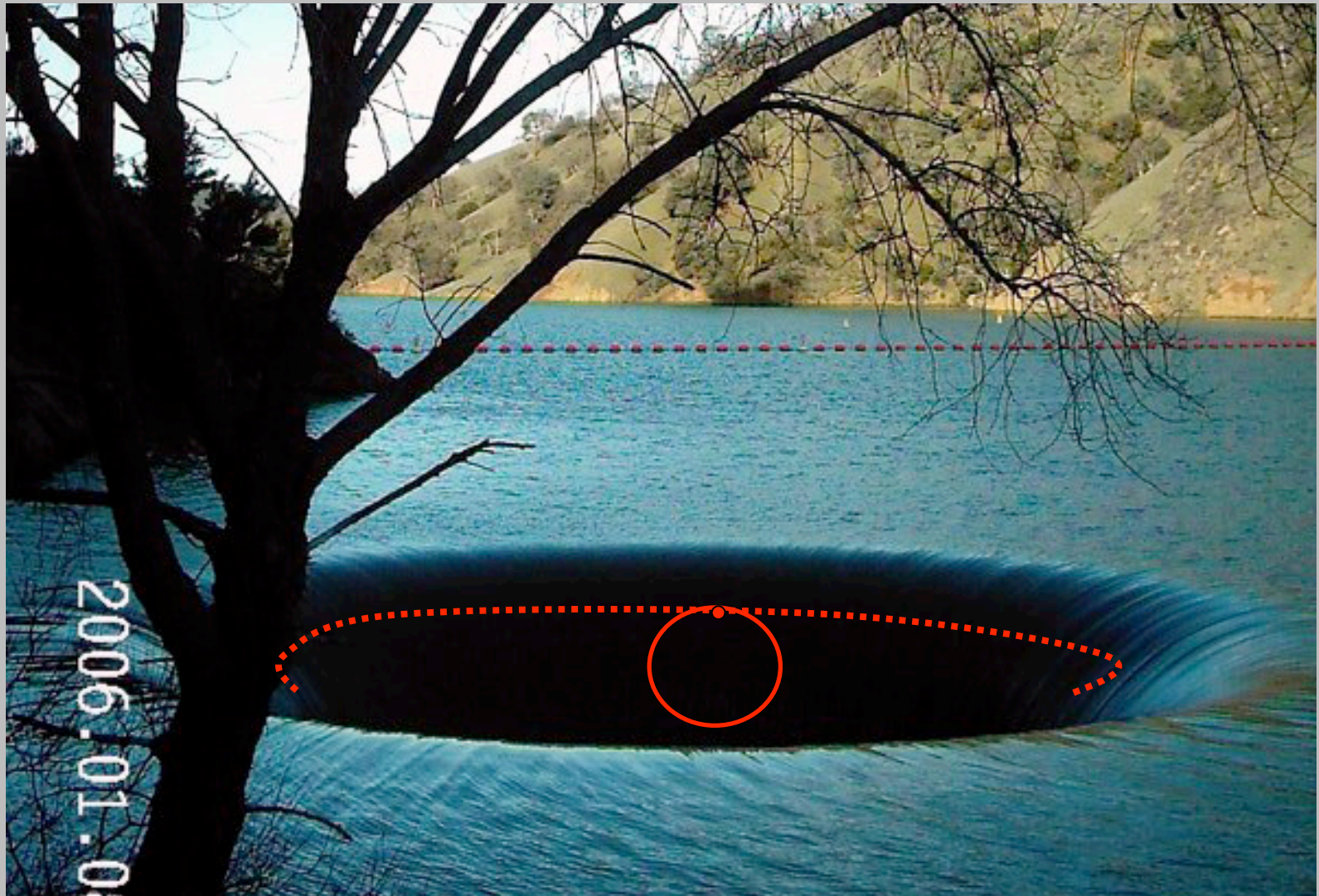

A black hole analogy

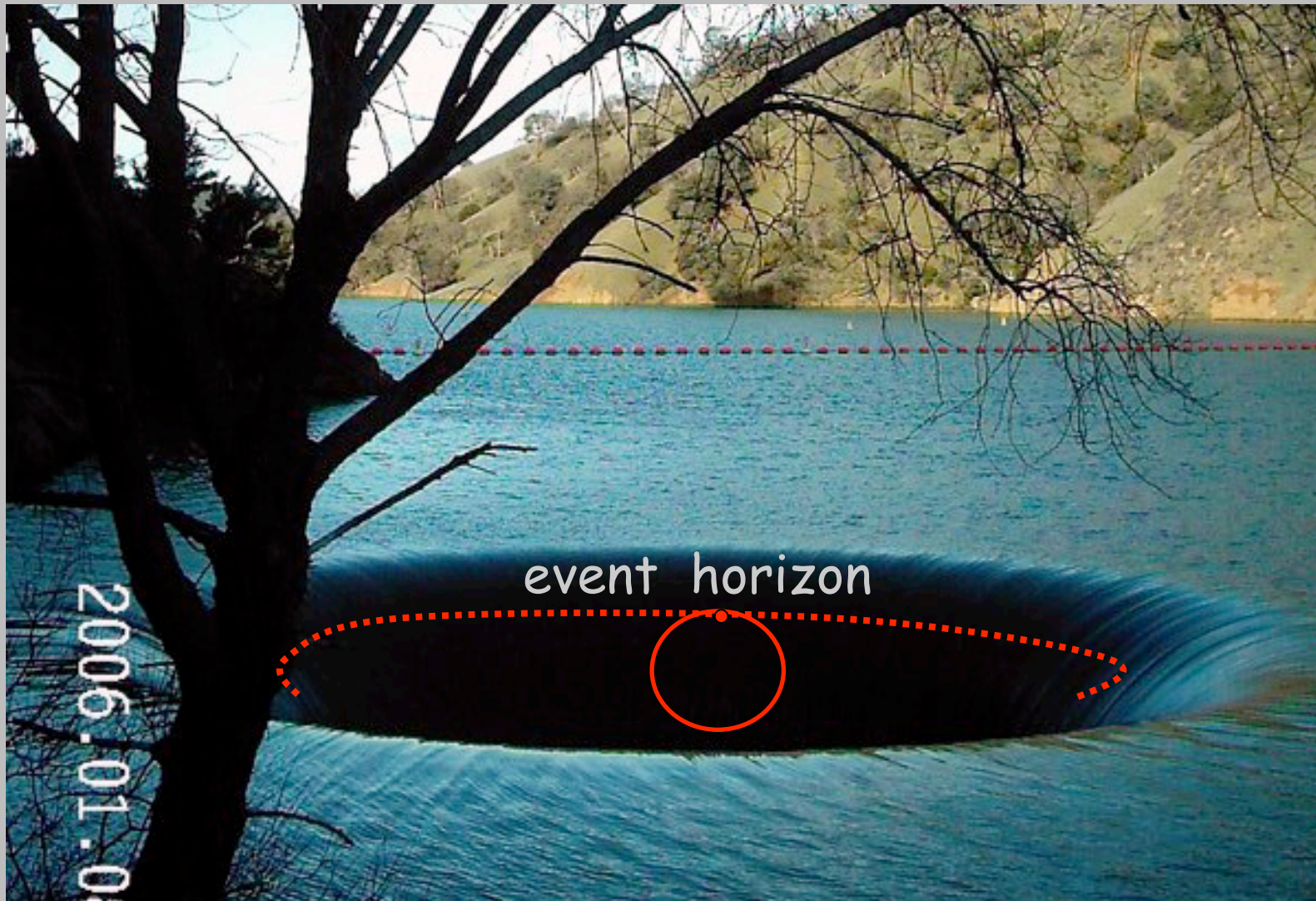

Spacetime picture
of an event horizon

Event
horizon

time



increasing radius →

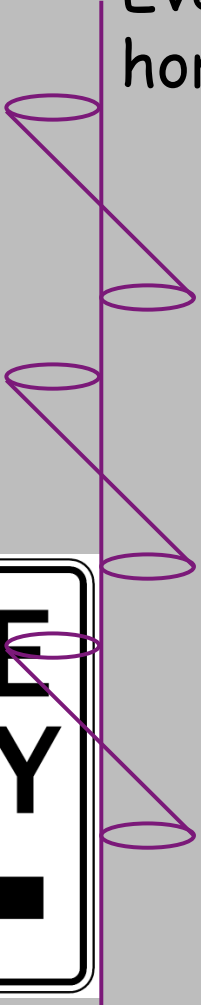

Could a black hole ever arise in nature?

Four persistent sources of confusion:

Mathematical: coordinate breakdown misunderstood

Physical: forces that support a star not fully understood

Psychological: insistence on *static* configurations of matter

Metaphysical: difficulty accepting existence of the unknown

The history of insights and confusion is complicated and fascinating –
(cf. Werner Israel's "Dark Stars: The Evolution of an Idea")

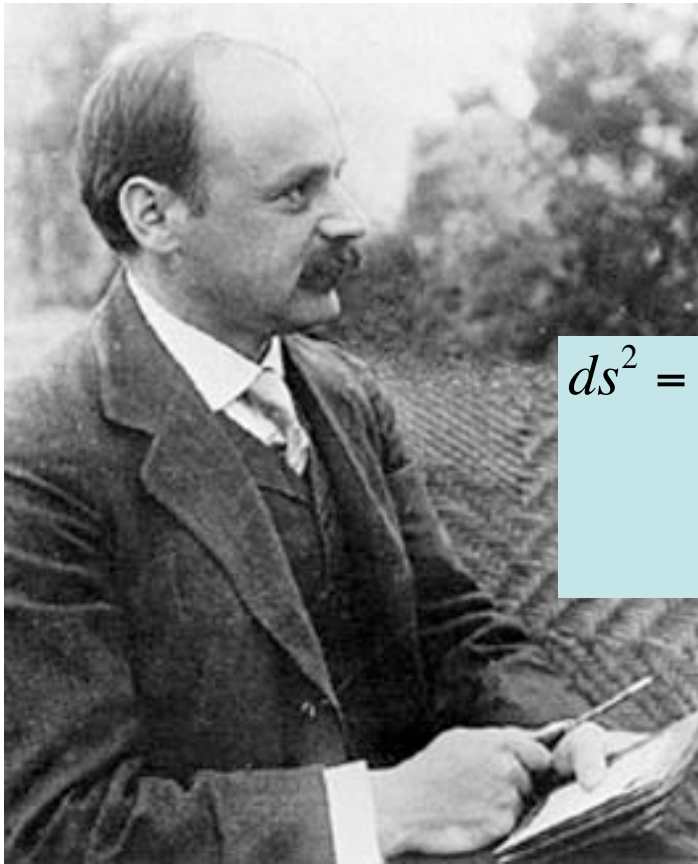

The Schwarzschild Singularity (1916)

$$ds^2 = (1 - r_s/r)dt^2 - (1 - r_s/r)^{-1}dr^2 - r^2(d\theta^2 + \sin^2\theta d\varphi^2)$$

$$r_s = 2GM/c^2 \quad \text{"Schwarzschild radius"}$$

The true, non-singular nature of the Schwarzschild "singularity" was not widely understood until 42 years later..

Georges Lemaitre

First person to understand the nature of the Schwarzschild singularity as an event horizon (1933).

Belgian mathematician and physicist, catholic priest, President of Pontifical Academy of Sciences 1960-66

Educated at Cambridge and MIT

Inventor of physical cosmology:

Expanding universe, cosmic fireball, origin of structure from quantum fluctuations, beginning of time...

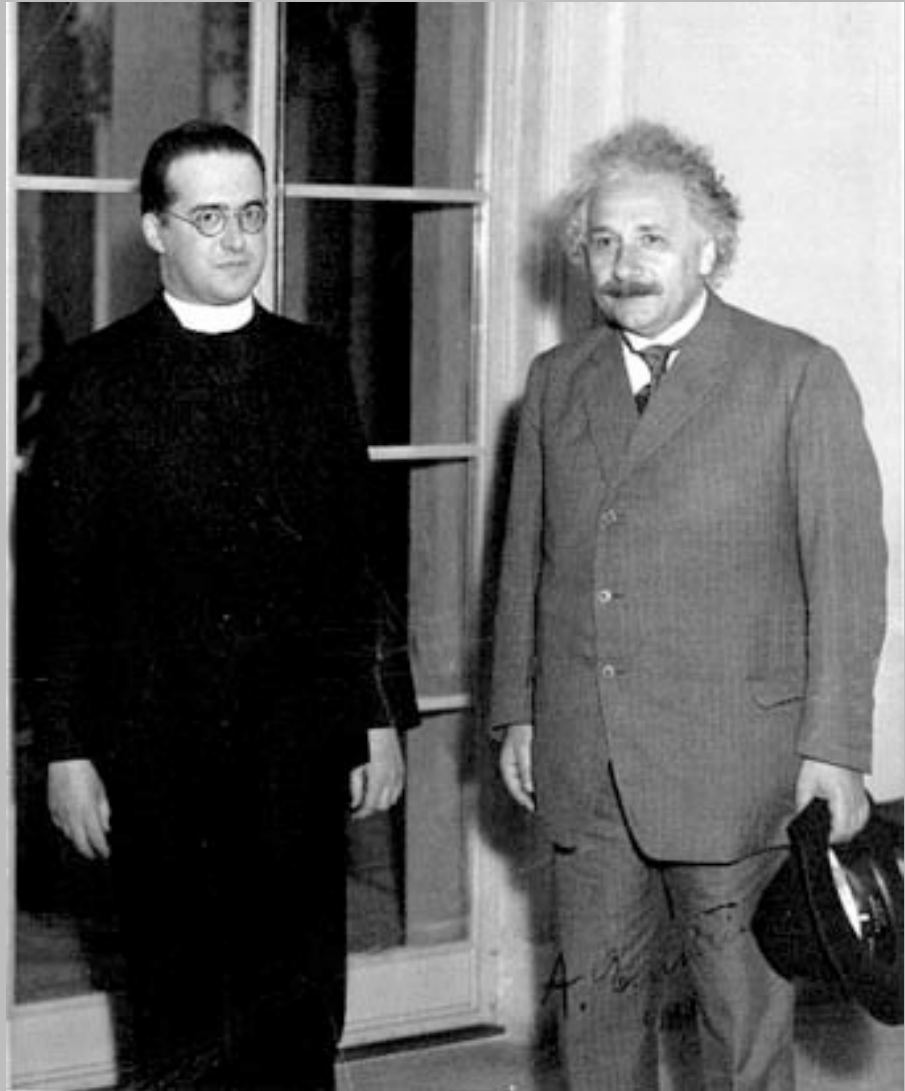

Why was Lemaitre not confused?

Mathematical: coordinate breakdown misunderstood
he was mathematically brilliant

Physical: lack of knowledge about the forces that support a star
he was focused on the cosmos, which is mostly empty space

Psychological: insistence on static configurations
he was focused on the cosmos, which is expanding

Metaphysical: difficulty accepting existence of the unknown
what lies behind a cosmological horizon is more of the same

Einstein (1939) repeated his earlier, cosmological error, insisting on stationary matter configurations.

ANNALS OF MATHEMATICS
Vol. 40, No. 4, October, 1939

ON A STATIONARY SYSTEM WITH SPHERICAL SYMMETRY
CONSISTING OF MANY GRAVITATING MASSES

BY ALBERT EINSTEIN

(Received May 10, 1939)

The essential result of this investigation is a clear understanding as to why the “Schwarzschild singularities” do not exist in physical reality. Although the theory given here treats only clusters whose particles move along circular paths it does not seem to be subject to reasonable doubt that more general cases will have analogous results. The “Schwarzschild singularity” does not appear for the reason that matter cannot be concentrated arbitrarily. And this is due to the fact that otherwise the constituting particles would reach the velocity of light.

Oppenheimer and Snyder (1939) analyzed collapsing matter and showed how an event horizon forms in a finite time.

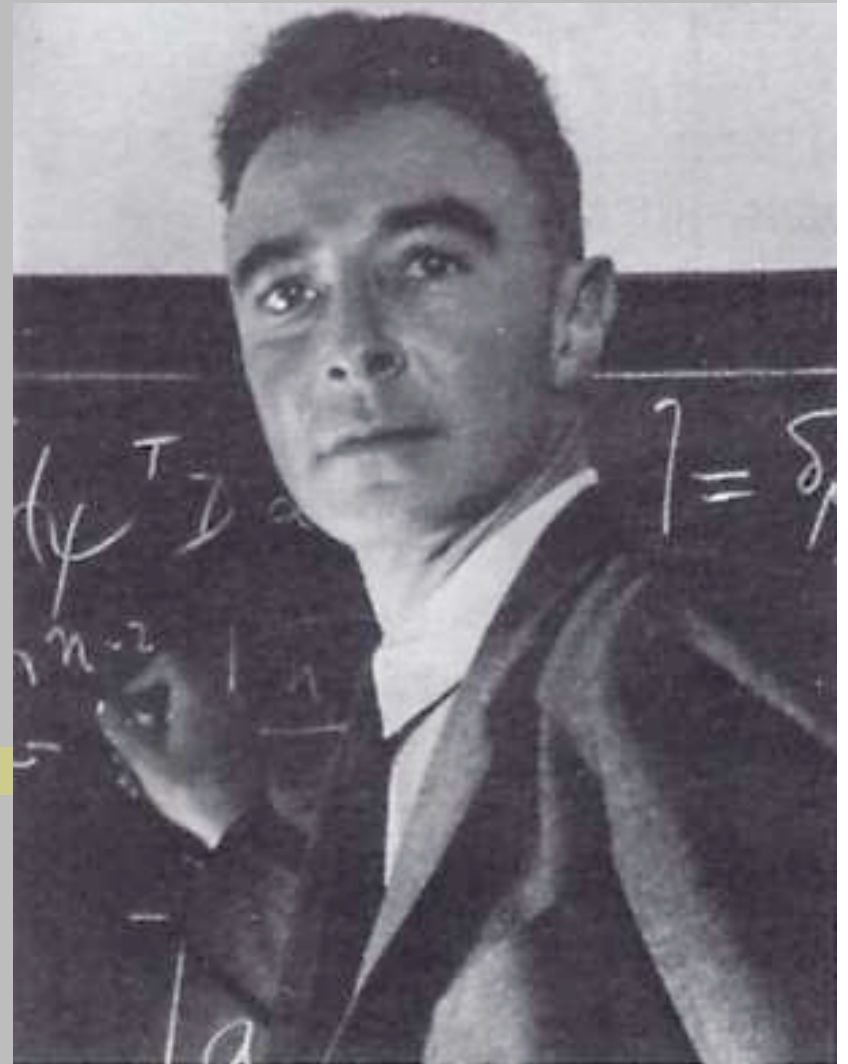

Oppenheimer and Snyder (1939) analyzed *collapsing* matter and showed how an event horizon forms in a finite time.

SEPTEMBER 1, 1939

PHYSICAL REVIEW

VOLUME 56

On Continued Gravitational Contraction

J. R. OPPENHEIMER AND H. SNYDER
University of California, Berkeley, California
(Received July 10, 1939)

When all thermonuclear sources of energy are exhausted a sufficiently heavy star will collapse. Unless fission due to rotation, the radiation of mass, or the blowing off of mass by radiation, reduce the star's mass to the order of that of the sun, this contraction will continue indefinitely. In the present paper we study the solutions of the gravitational field equations which describe this process. In I, general and qualitative arguments are given on the behavior of the metrical tensor as the contraction progresses: the radius of the star approaches asymptotically its gravitational radius; light from the surface of the star is progressively reddened, and can escape over a progressively narrower range of angles. In II, an analytic solution of the field equations confirming these general arguments is obtained for the case that the pressure within the star can be neglected. The total time of collapse for an observer comoving with the stellar matter is finite, and for this idealized case and typical stellar masses, of the order of a day; an external observer sees the star asymptotically shrinking to its gravitational radius.

First paper to discuss the viewpoint of an observer who falls in, and contrasted with the view of an external observer.

Twenty years later, it still wasn't accepted.

Oppenheimer, at 1958 Solvay Congress:

“Would not the simplest assumption about the fate of a star more than the critical mass be this, that it undergoes continued gravitational contraction and cuts itself off from the rest of the universe?”

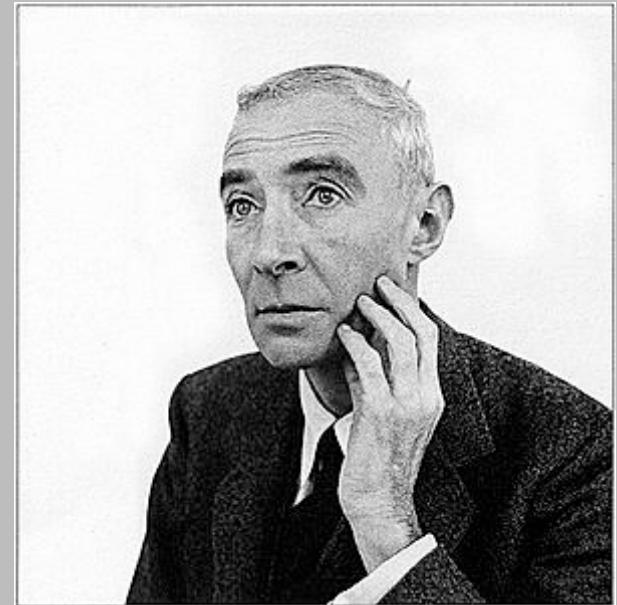

Oppenheimer, 1958
by Richard Avedon,
currently on display at
The Corcoran Gallery

Why was Oppenheimer not confused?

Mathematical: coordinate breakdown misunderstood
he was not looking at the static solution

Physical: lack of knowledge about the forces that support a star
1) he had just previously found an upper limit for the mass of stars supported by nuclear matter,
2) he simplified the problem by neglecting pressure!

Psychological: insistence on static configurations
he was convinced by his previous work that the star could not remain static

Metaphysical: difficulty accepting existence of the unknown

Why was Oppenheimer not **metaphysically** confused?

Oppenheimer “worked at physics,” Bethe told a biographer, “mainly because he found physics the best way to do philosophy.”

From article by Richard Rhodes, American Heritage vol. 28, #6, October 1977

I.I. Rabi wrote:

“....It seems to me that in some respects Oppenheimer was overeducated in those fields which lie outside the scientific tradition, such as his interest in religion, in the Hindu religion in particular, which resulted in a feeling for the mystery of the universe that surrounded him almost like a fog. He saw physics clearly, looking toward what had already been done, but at the border he tended to feel that there was much more of the mysterious and novel than there actually was....”

Still missing was a *picture* of the spacetime structure...

Past-Future Asymmetry of the Gravitational Field of a Point Particle

DAVID FINKELSTEIN

Stevens Institute of Technology, Hoboken, New Jersey, and New York University, New York, New York

(Received January 9, 1958)

The analytic extension of the Schwarzschild exterior solution is given in a closed form valid throughout empty space-time and possessing no irregularities except that at the origin. The gravitational field of a spherical point particle is then seen not to be invariant under time reversal for any admissible choice of time coordinate. The Schwarzschild surface $r=2m$ is not a singularity but acts as a perfect unidirectional membrane: causal influences can cross it but only in one direction. The apparent violation of the principle of sufficient reason seems similar to that which is associated with instabilities in other nonlinear phenomena.

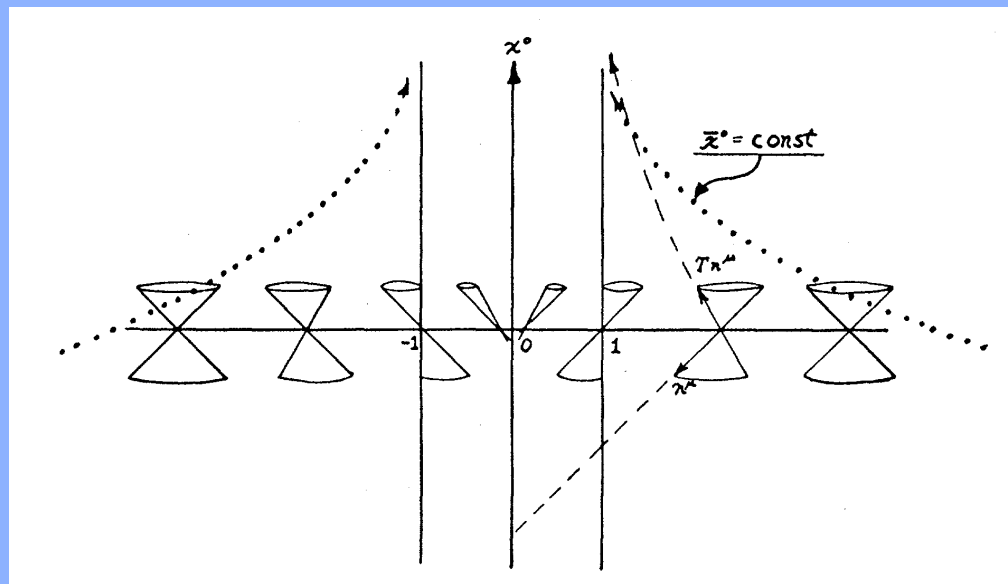

The combined outside-inside view visualized...

Past-Future Asymmetry of the Gravitational Field of a Point Particle

DAVID FINKELSTEIN

Stevens Institute of Technology, Hoboken, New Jersey, and New York University, New York, New York

(Received January 9, 1958)

The analytic extension of the Schwarzschild exterior solution is given in a closed form valid throughout empty space-time and possessing no irregularities except that at the origin. The gravitational field of a spherical point particle is then seen not to be invariant under time reversal for any admissible choice of time coordinate. The Schwarzschild surface $r=2m$ is not a singularity but acts as a perfect unidirectional membrane: causal influences can cross it but only in one direction. The apparent violation of the principle of sufficient reason seems similar to that which is associated with instabilities in other nonlinear phenomena.

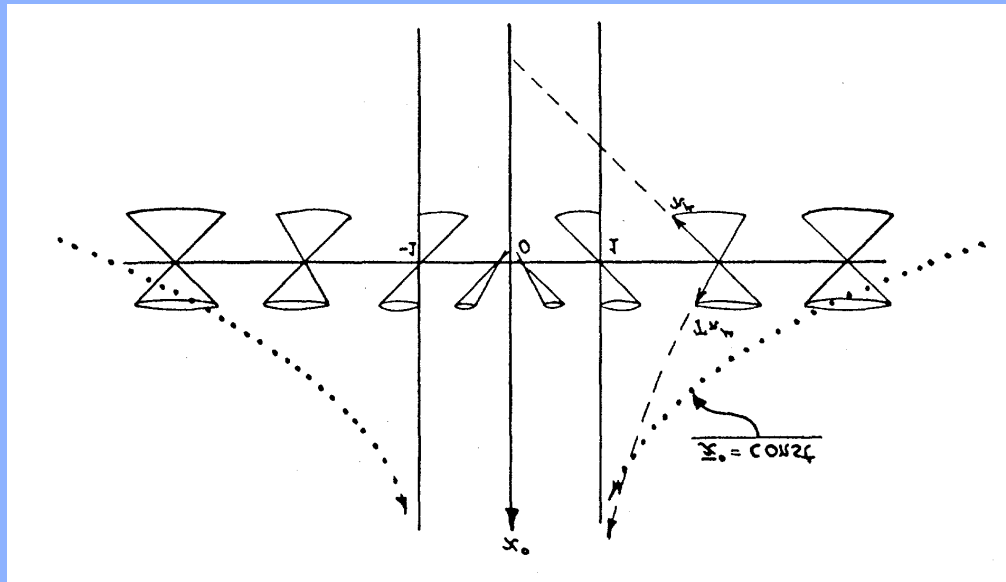

The combined outside-inside view visualized...

Penrose singularity theorem (1964)

Once a trapped surface forms, a singularity is inevitable, regardless of spherical symmetry.

"When eventually we have a better theory of nature, then perhaps we can try our hands again, at understanding the extraordinary physics which must take place at a space-time singularity."
(Penrose, 1969)

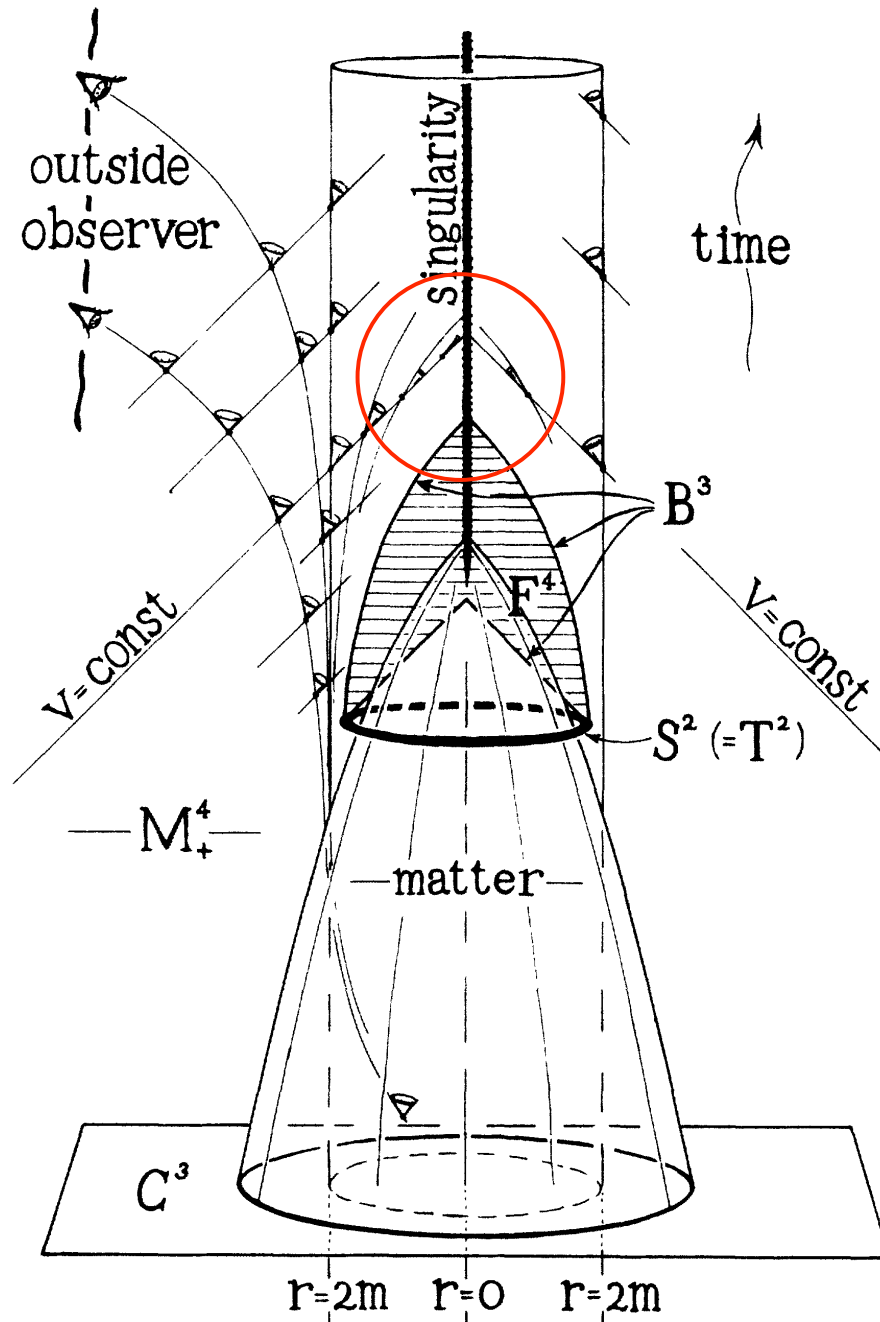

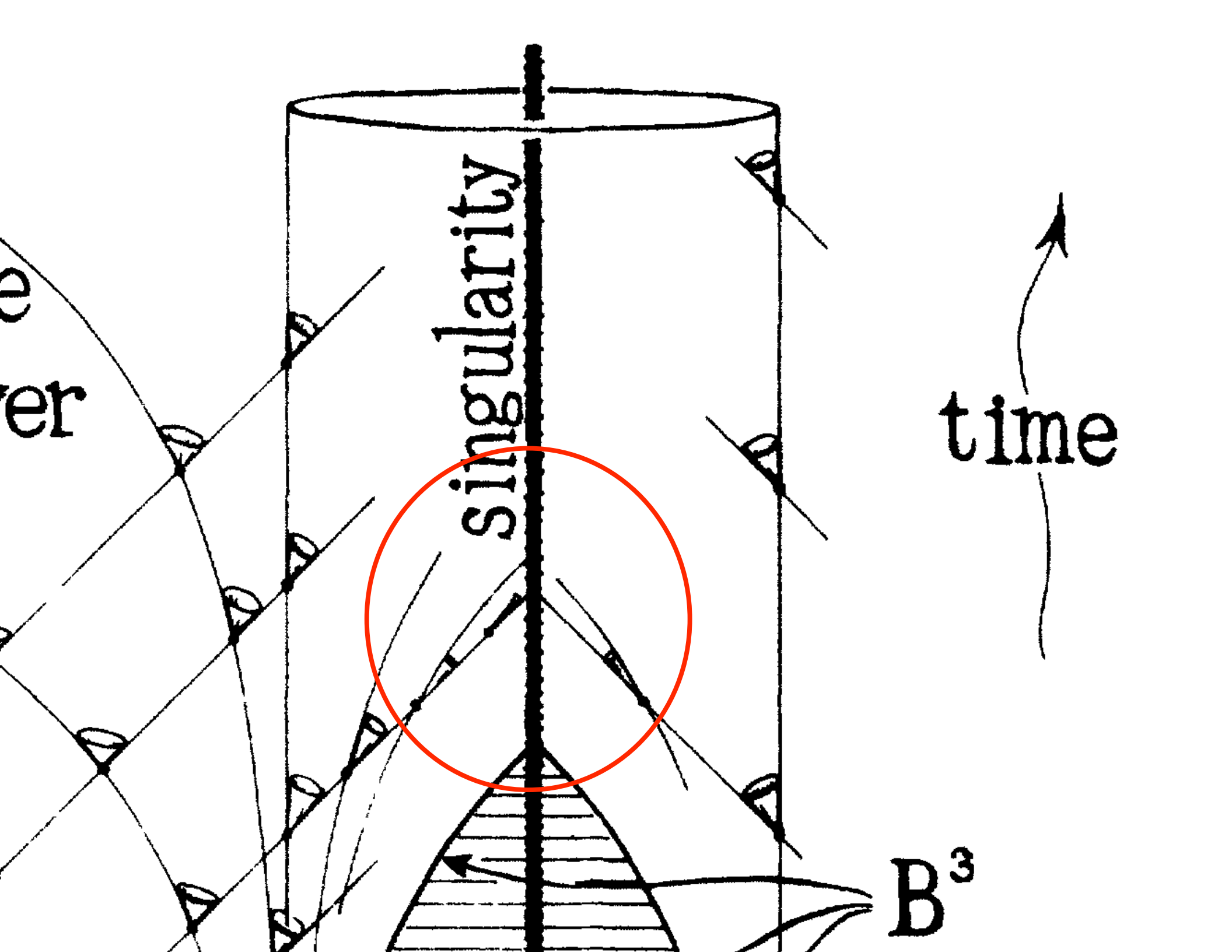

Fate of a black hole singularity?

The End

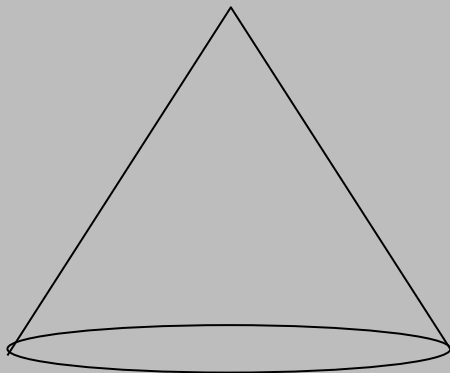

time ends

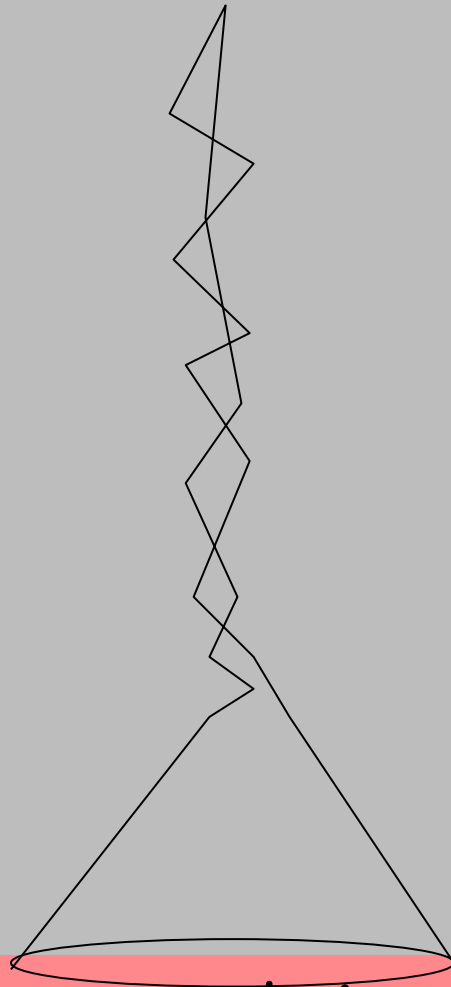

fractured time
continues

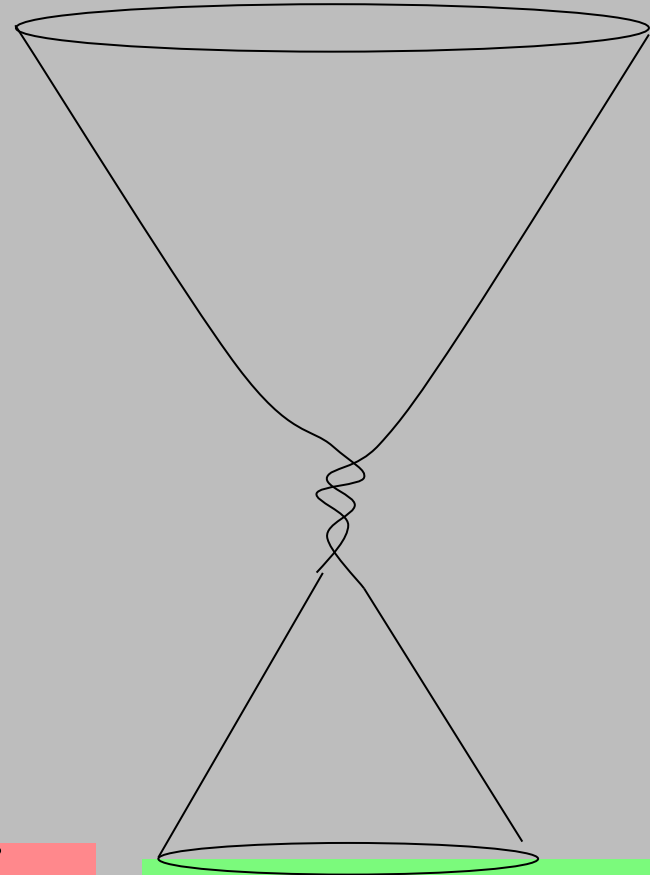

plump baby
Universe born

“Black hole” nucleation in a splash of milk

Laurent Courbin, James C. Bird, Andrew Belmonte, and Howard A. Stone

From a simple bounce

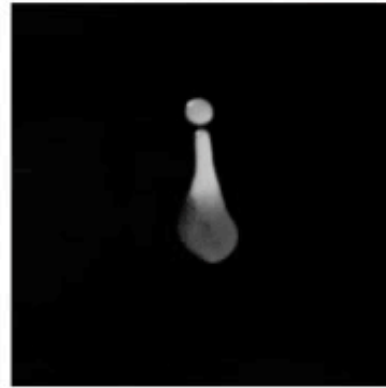

to

“spiders”

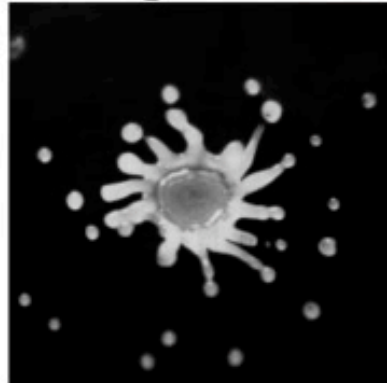

&

“black holes”

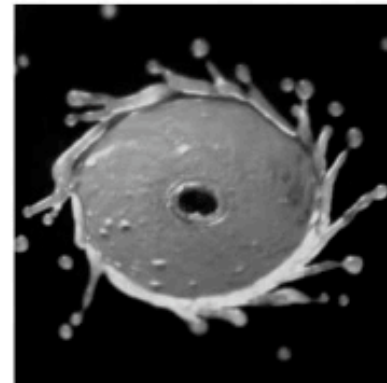

Will we ever see what happens at a singularity?

Does “cosmic censorship” hold?

Will we see mini black holes
explode from Hawking radiation?

Was the big bang a black hole singularity?

The outside view...



"It's black, and it looks like a hole.
I'd say it's a black hole."

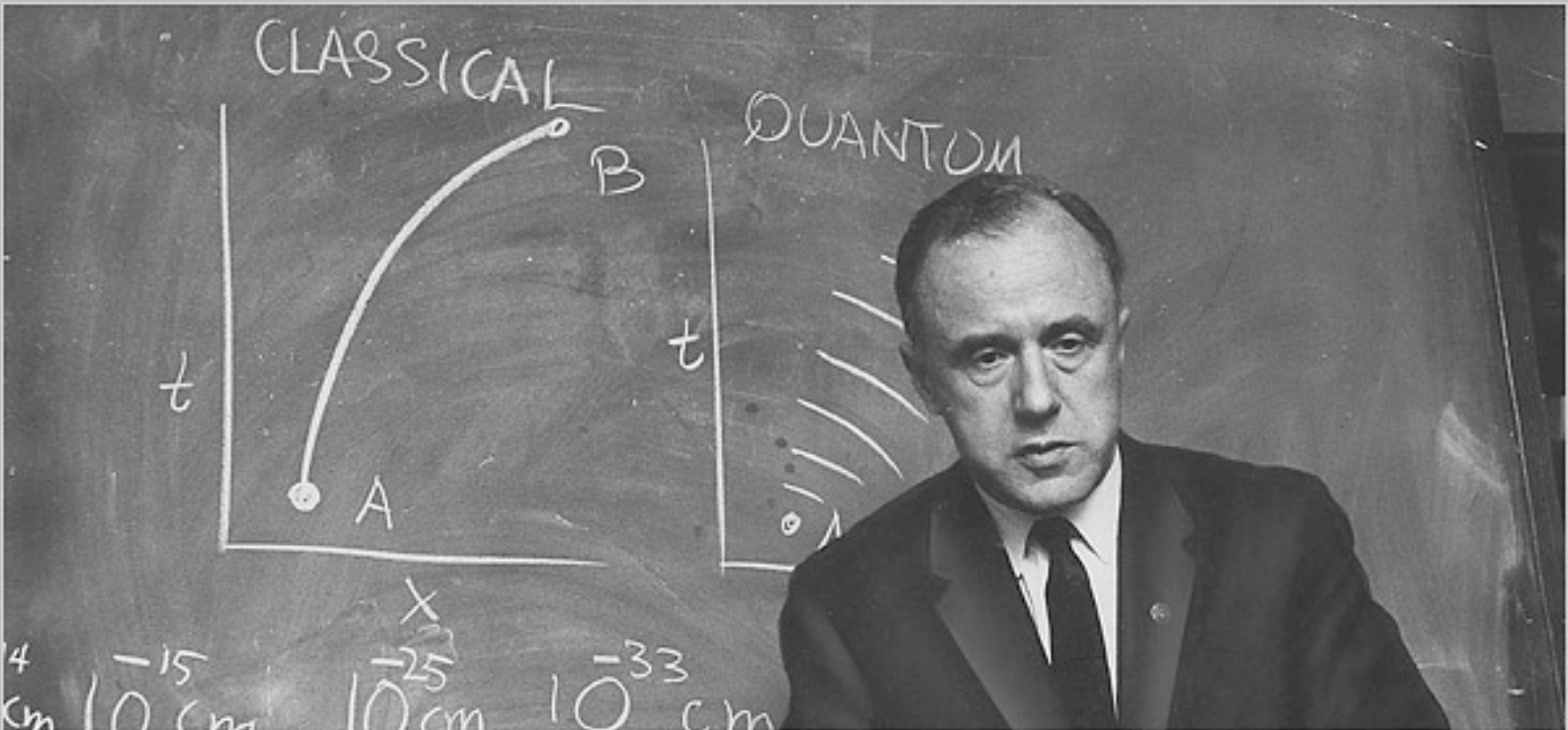

In the fall of 1967, he was invited to give a talk on pulsars, then-mysterious deep-space objects, at NASA's Goddard Institute of Space Studies in New York. As he spoke, he argued that something strange might be at the center, what he called a gravitationally completely collapsed object. But such a phrase was a mouthful, he said, wishing aloud for a better name. "How about black hole?" someone shouted from the audience.

"I had been searching for just the right term for months, mulling it over in bed, in the bathtub, in my car, wherever I had quiet moments," he later said. "Suddenly this name seemed exactly right."

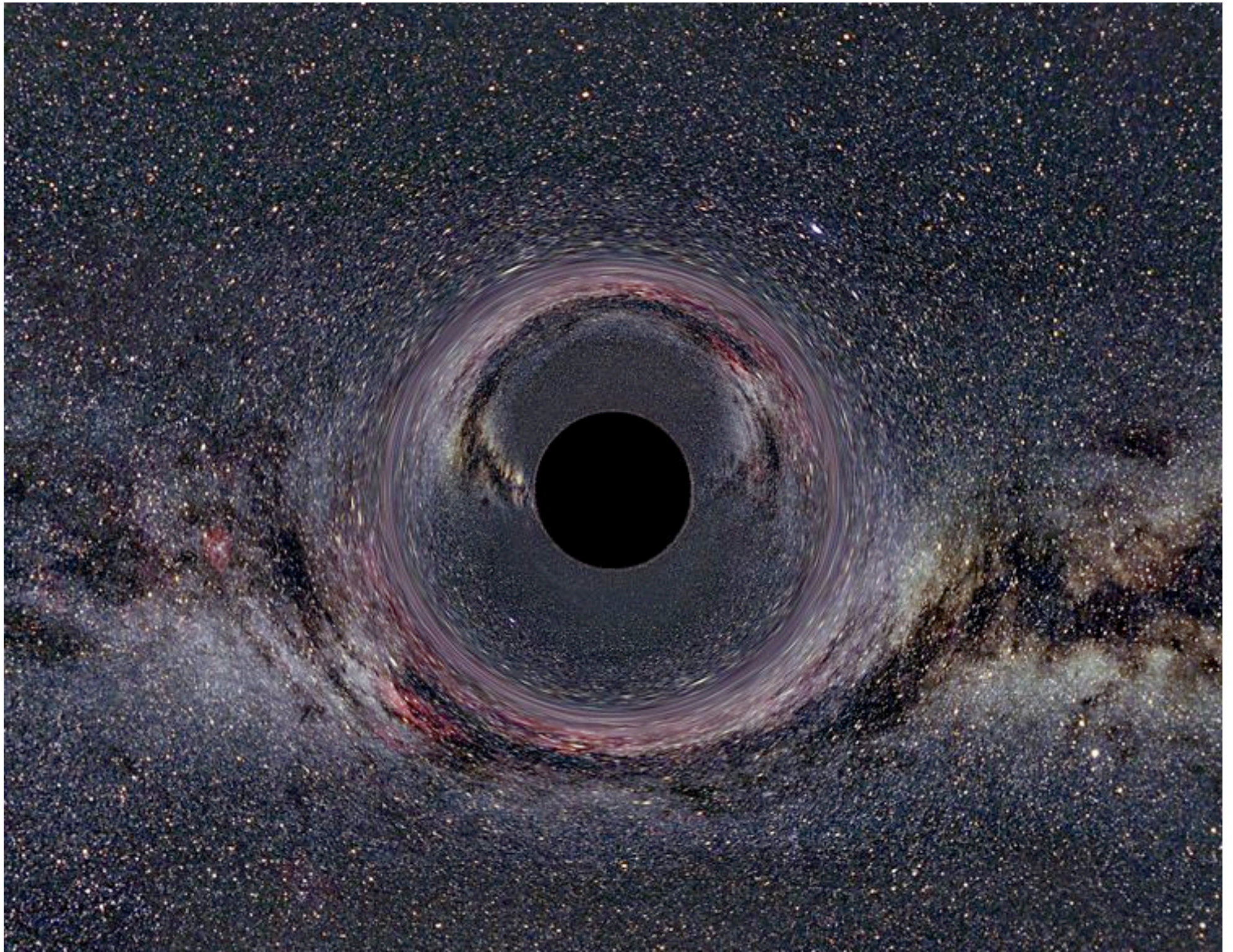

Jet, probably from rapidly spinning
3 billion solar mass black hole



M87, in Virgo cluster, 60 million light years away,
jet > 5000 ly long

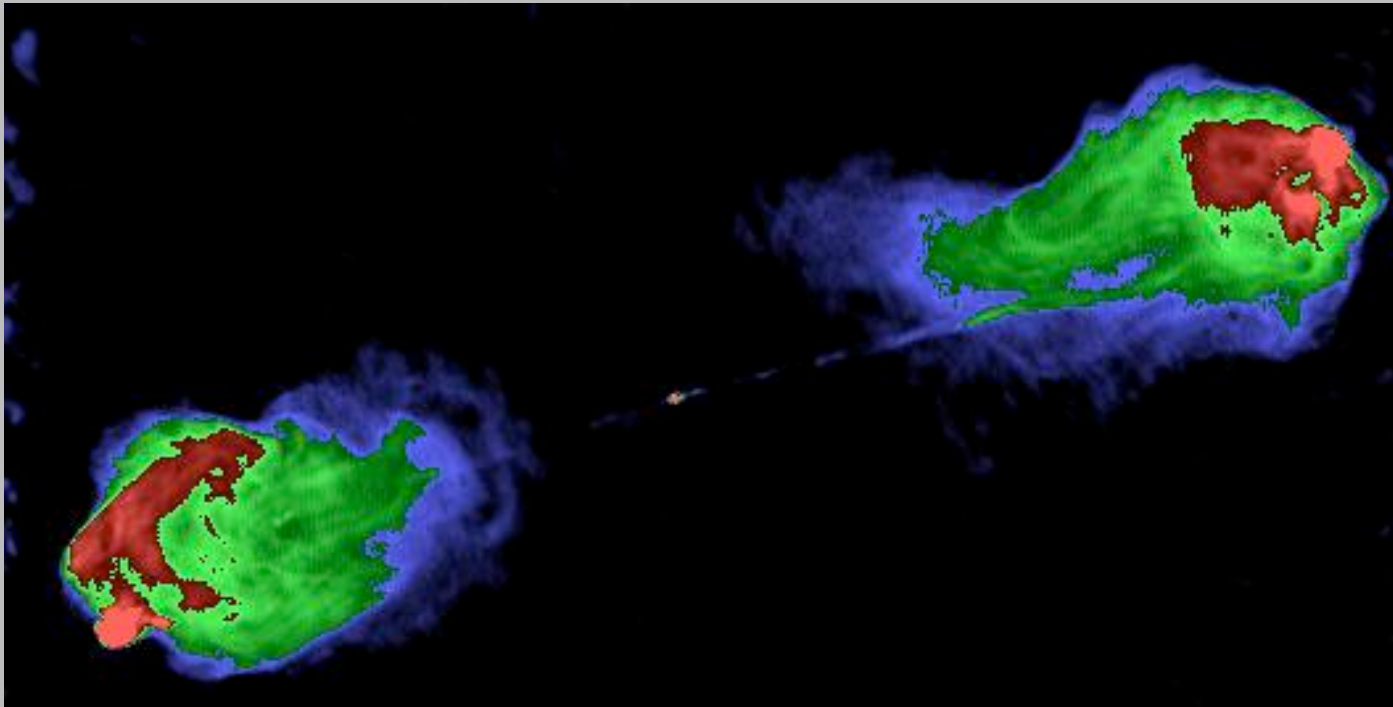

5-GHz radio image of Cygnus A (3C405), from VLA data.
600 million light years away.

Energy source: gravity and/or spin energy of black hole

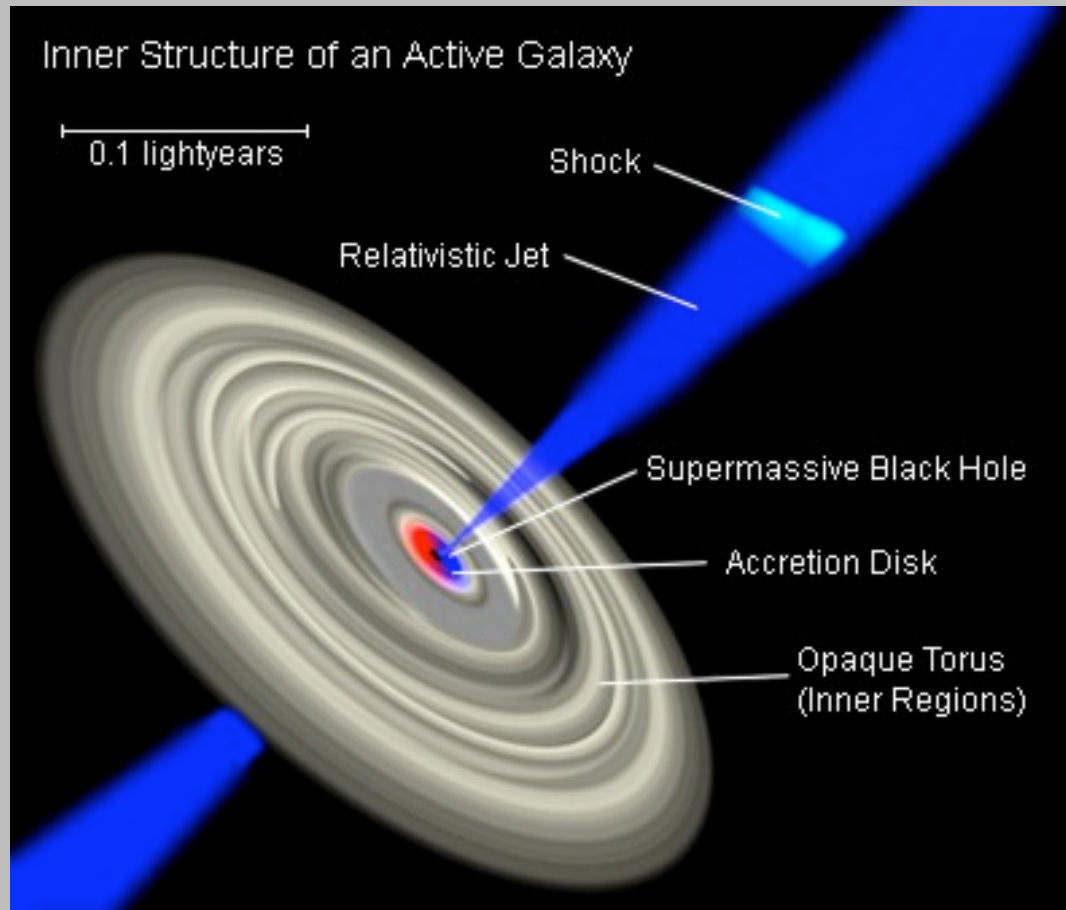

X-ray reflection spectroscopy

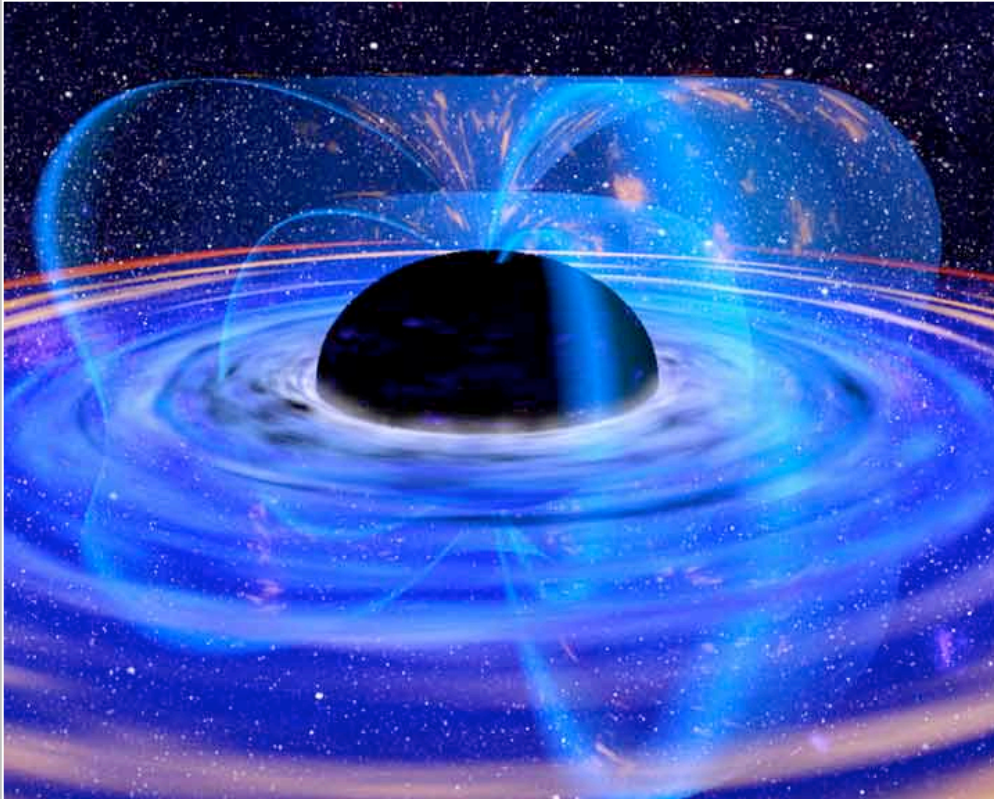

X-rays from
corona/jet
irradiate
accretion
disks...
creates a
backscattered
spectrum rich
in spectral
features

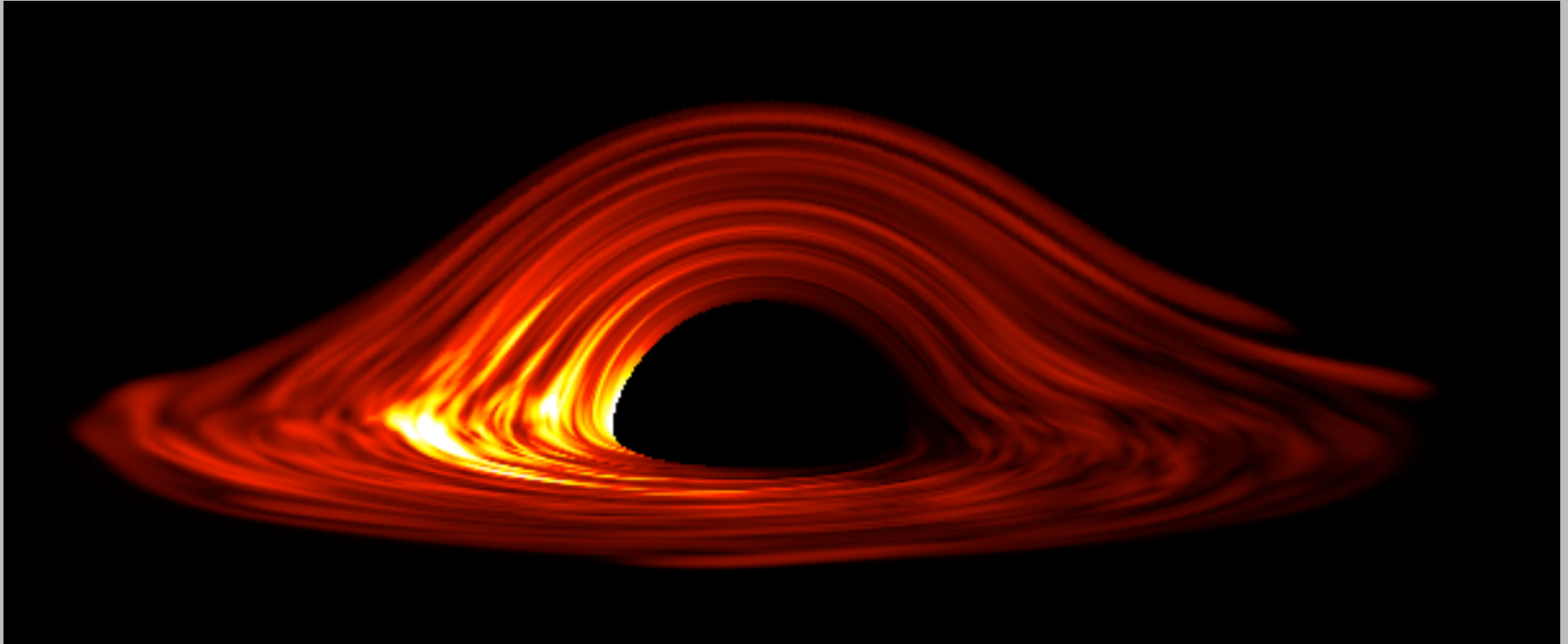

Picture by Chris Reynolds, UMD Astronomy Dept.

Computer-generated image of a turbulent accretion disk surrounding a Schwarzschild black hole (80 degree viewing inclination)...

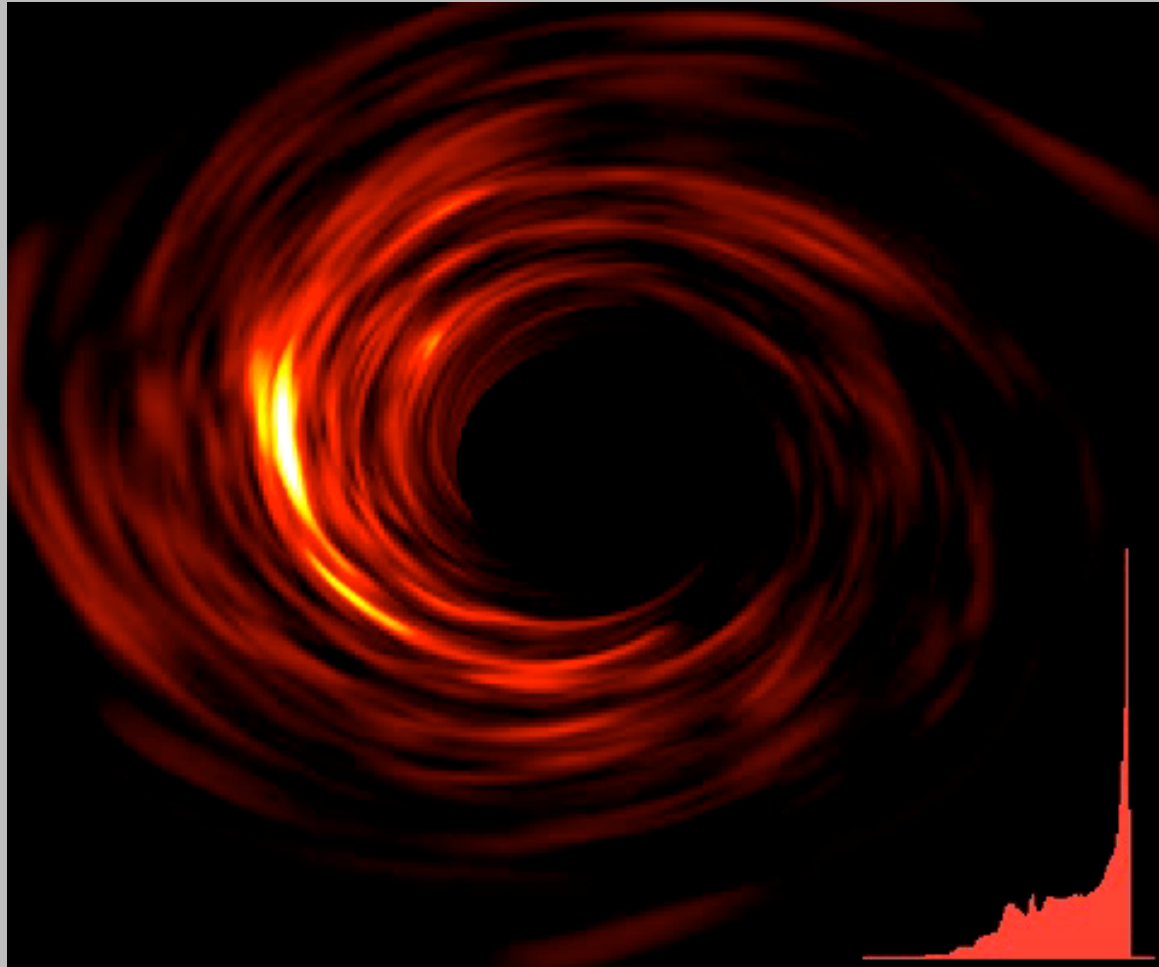

Animation by Chris Reynolds, UMD Astronomy Dept.

Animation of MHD turbulent accretion disk around Schwarzschild black hole (30 degree viewing inclination) - Bottom right shows the iron line profile that results.

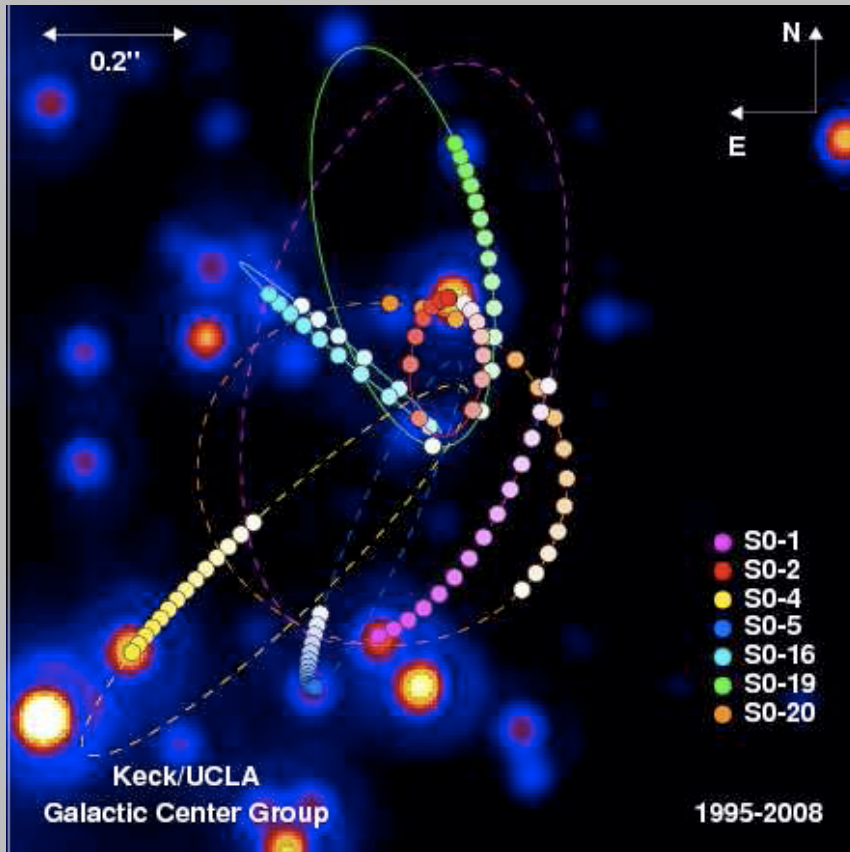

Orbits of stars around center of Milky Way galaxy

All orbits fit the same central mass of ~ 4 million M_{sun} at the position of the radio source Saggiarius A*.

(Image courtesy A. Ghez.)

IS THERE A SUPERMASSIVE BLACK HOLE AT THE CENTER OF THE MILKY WAY?

Mark J. Reid

*Harvard-Smithsonian Center for Astrophysics
60 Garden Street, Cambridge, MA 02138, USA
mreid@cfa.harvard.edu*

Received 2008 August 18

9. Summary

The major observational results that provide overwhelming evidence that Sgr A* is a SMBH are as follows:

- Stars near Sgr A* move on elliptical orbits with a common focal position.
- The required central mass is $4 \times 10^6 M_{\odot}$ within a radius of 100 AU.
- The position of Sgr A* agrees with the orbital focus to within measurement uncertainty of ± 80 AU.
- The infrared emission from Sgr A* is far less luminous than a single star.
- The intrinsic size of Sgr A* at mm-wavelengths is $< 6R_{\text{Sch}}$.
- Sgr A* is intrinsically motionless at the km s^{-1} level at the dynamical center of the Galaxy.

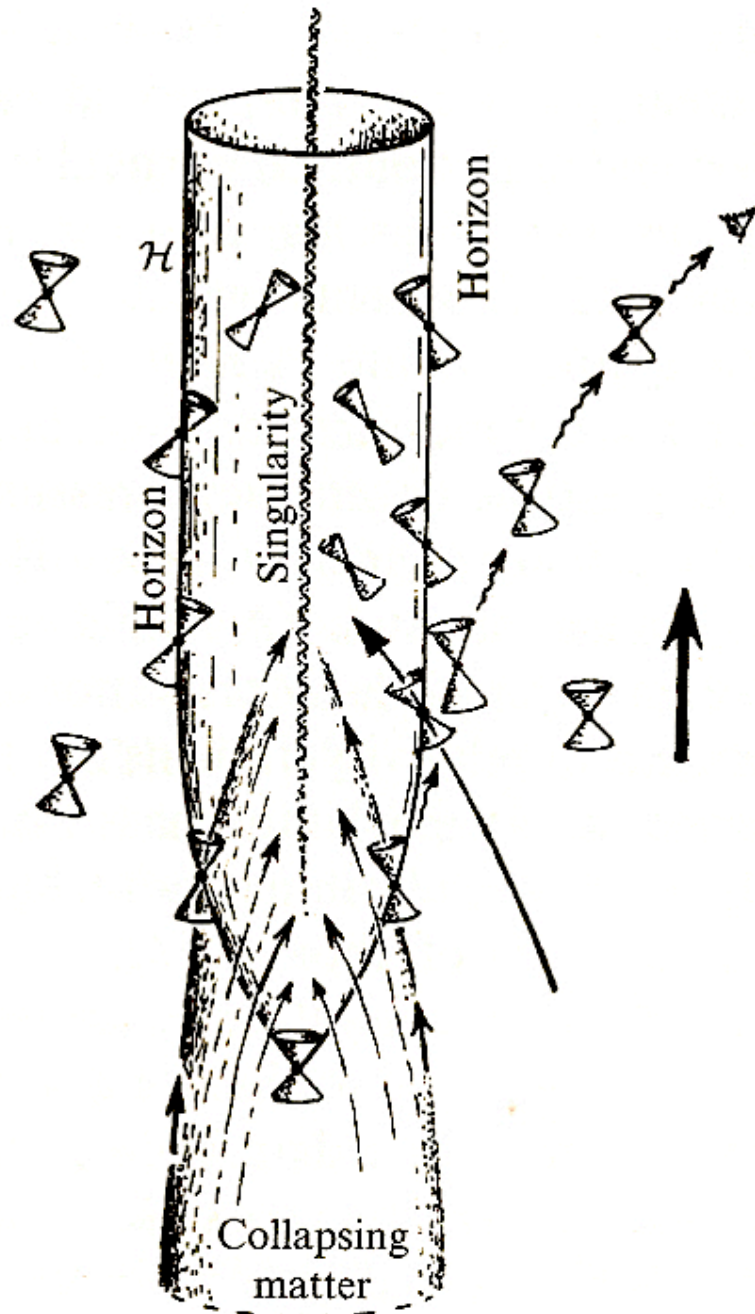

Black Holes and Warped Spacetime

Ted Jacobson

Picture by Roger Penrose
The Road to Reality (Knopf, 2005)